

# Norstar Applications Module Installation and Maintenance Manual

Norstar is a trademark of Nortel Networks.  
© Copyright Nortel Networks, 1999

1-800-4 NORTEL  
[www.nortel.com/norstar](http://www.nortel.com/norstar)

Norstar is a trademark of Nortel Networks.  
P0908822 Issue 01  
Printed in Canada

## Regulatory information

.The Norstar Applications Server generates radio frequency energy, and if not installed and used in accordance with the instruction manual, may cause interference to radio communications. It has been tested and found to comply with the limits for a Class A computing device pursuant to Part 15 of the FCC rules and CSA specification C108.8, which are designed to provide reasonable protection against such interference when operated in a commercial environment. Operation of this equipment in a residential area is likely to cause interference, in which case users will be required, at their own expense, to take whatever measures necessary to correct the interference.

This apparatus does not exceed the Class A limits for radio noise emissions from digital apparatus set out in the Radio Interference Regulations for the Canadian Department of Communications.

This equipment has been verified to comply with the limits for Class A computing device, pursuant to FCC, Subpart B, and ICES-003 Canadian EMI requirements with the peripherals recommended by Nortel for use with this equipment.

To resolve problems with interference resulting from use of peripherals not specifically marketed by or recommended by Nortel, contact the manufacturer or dealer of that peripheral for assistance. Only peripherals (computer input/output devices, terminals, printers etc.) certified to comply with Class A limits may be attached to this computer. Operation with non-certified peripherals is likely to result in interference to radio and television reception.

**CAUTION**

The Norstar Applications Module contains fragile electronic parts. DO NOT DROP OR BUMP THE MODULE.

## Repair facilities

In the event of equipment malfunction, all repairs will be performed by Northern Telecom or by one of its authorized dealers.

In the USA	In Canada
Northern Telecom Inc. Nashville Repair and Distribution Center 640 Massman Drive Nashville, TN 37210	Northern Telecom Canada Ltd. 30 Norelco Drive Weston, ON M9L 2X6
Attn: RA# Tel: (615) 883-9220	Tel: (416) 744-5201 Fax: (416) 744-5227

**Note:** You will receive an RA# when you call the repair center in Nashville. This number should appear on the package of any and all parts sent to this location for repair.

---

# Table of Contents

	<b>Regulatory information</b>	iii
	Repair facilities	iv
<b>Chapter 1</b>	<b>How to use this manual</b>	<b>9</b>
	Introduction	9
	How this manual is organized	9
	Knowing the symbols	10
<b>Chapter 2</b>	<b>Components of the Norstar Applications Module (NAM)</b>	<b>13</b>
	NAM upgrades	13
	Single Board Computer (SBC)	13
	Media Services Base Interface Card (BIC)	14
	Hard disk drive	14
	Floppy disk drive	14
	Connection Ports	15
	Optional equipment	16
	About the System software	17
<b>Chapter 3</b>	<b>Installing the Norstar Applications Module (NAM)</b>	<b>21</b>
	Introduction	21
	Before you start	21
	Packaging Checklist	21
	Environment Checklist	22
	Special parts and equipment	22
	Other documentation	22
	Installation overview	23
	Changing the power supply voltage	23
	Mounting the NAM on the wall	23
	Floor mount stand	25
	Assembling the floor mount stand	25
	Attaching the floor mount stand to the NAM	26
	Installing the end-caps	27
	Connecting the NAM to the KSU	27
	Fiber cable precautions	28
	Starting the NAM	29
<b>Chapter 4</b>	<b>Preparing for the upgrade</b>	<b>33</b>
	Overview	33
	Special tools	34
	Shutting down the NAM	34

	Accessing the inside of the NAM	35
	Removing the front cover	36
	Opening the cable trough	37
	Removing the plastic case	37
<b>Chapter 5</b>	<b>Installing the clock/calendar battery</b>	<b>39</b>
	Overview	39
	Removing and replacing the battery	39
<b>Chapter 6</b>	<b>Installing the Digital Fax Card (DFC)</b>	<b>41</b>
	Overview	41
	Precautions	42
	Installing the DFC	42
	Installing the Media Services Bus Expansion Card (BEC) on the BIC	44
	Connecting the DFC to the BIC with the PEB Cable	46
	Removing fax functionality from the System	48
<b>Chapter 7</b>	<b>Installing and upgrading the Media Services Base Interface Card (BIC)</b>	<b>51</b>
	Overview	51
	Increasing the number of Voice Channels	51
	Installing a PEC in the NAM	52
	Removing the BIC	54
	Re-installing the BIC	54
<b>Chapter 8</b>	<b>Installing a new floppy disk drive</b>	<b>57</b>
	Overview	57
	Installing a new floppy disk drive	57
<b>Chapter 9</b>	<b>Installing and upgrading the hard disk drive</b>	<b>59</b>
	Overview	59
	Backing up the NAM capabilities file	59
	Removing the hard disk drive	60
	Installing a new hard disk drive	62
	Restoring the NAM capabilities file	63
	Adding a secondary hard disk drive	64
<b>Chapter 10</b>	<b>Adding and replacing memory</b>	<b>67</b>
	Overview	67
	Adding memory	67
	Removing memory	70
<b>Chapter 11</b>	<b>Adding and removing a monitor, keyboard and mouse</b>	<b>73</b>
	Overview	73

	Connecting the monitor, keyboard and mouse	73
	Enabling the monitor, keyboard and mouse	74
	Removing the monitor, keyboard and mouse	75
<b>Chapter 12</b>	<b>Changing the power supply voltage</b>	<b>77</b>
<b>Chapter 13</b>	<b>Installing and replacing the Single Board Computer (SBC)</b>	<b>79</b>
	Overview	79
	Removing and replacing the SBC	80
<b>Chapter 14</b>	<b>ACCESS Server Administration software</b>	<b>85</b>
	Overview	85
	Using the ACCESS Server Administration software	86
	Changing the printer options	86
	Setting the DTMF digit duration length	86
	Viewing the Alarm and Message Log	87
	Sharing Voice and Fax Channels between applications	88
	Installing applications	91
	<b>Viewing the NAM serial number</b>	<b>91</b>
	Shutting down the NAM	92
	Rebooting the NAM	92
	Allocating and restricting hard disk drive space	94
	Line renumbering	95
	Resetting the Line Answer status	96
<b>Chapter 15</b>	<b>Troubleshooting</b>	<b>101</b>
	Overview	101
	Diagnosing problems	101
	Hardware problems	101
	Checking the Channel Status	103
	Disabling and Re-enabling Norstar Voice Mail Channels	106
	Preparing the NAM for travel	108
	<b>Glossary</b>	<b>109</b>
	<b>Index</b>	<b>117</b>

## Introduction

The NAM Installation and Maintenance Manual provides technical information and procedures required by a technician to install the NAM and perform various replacement and upgrade tasks. This manual is useful during and after an initial installation.

To use this manual, you should be:

- an experienced Norstar installer
- familiar with basic Norstar terminology

## How this manual is organized

The NAM Installation and Maintenance Manual is organized in five sections that cover:

**NAM Components** — This section provides an overview and functional description of NAM hardware, a description of the hardware components, and shows where the components are located.

**Installing the NAM** — This section provides the steps necessary to install a NAM.

**NAM Hardware Upgrades and Replacements** — This section provides the steps necessary for upgrading or replacing various NAM components.

**ACCESS Server administration** — This section explains how to use the ACCESS Server administration software for a variety of maintenance functions.

**Troubleshooting** — This section provides procedures for diagnosing and solving problems concerning the NAM.

## Knowing the symbols

This manual uses certain symbols to draw your attention to important information. You should pay attention to the following:



**Caution Symbol**

Alerts you to situations where there is the possibility of damaging the equipment.



**Warning Symbol**

Alerts you to situations where there is the possibility of injuring yourself

**Note:** A Note alerts you to information that is particularly critical or noteworthy.



Alerts you to remove the NAM power cord from the AC outlet before performing the maintenance procedure.



Alerts you to ground yourself before performing the maintenance procedure.

---

# Section I - Norstar Applications Module (NAM) Components

- Components of the NAM
  - NAM System software

---

# Components of the Norstar Applications Module (NAM)

## 2

The NAM consists of:

- 32 MB of SDRAM
- 3.5 in., 1.44 MB floppy disk drive
- 3.5 in. 2.1 GB IDE hard disk drive\*
- On-board SVGA video card
- On-board 10/100 Base T Ethernet Network Interface Card (NIC)
- Media Services Base Interface Card (BIC)
- OS/2 Warp™ operating system
- Norstar ACCESS Server software

\* 2.1 GB is the minimum hard disk drive size offering over 200 hours of message storage time.

The NAM is physically connected to the Norstar KSU by a fiber cable. The fiber cable allows the NAM to send instructional messages to the KSU and vice versa.

### NAM upgrades

The NAM can be upgraded to host a variety of hardware and software configurations. You can enhance functionality by adding more Voice Channels. Refer to "Installing the Norstar Applications Module (NAM)" on page 19 for more information about upgrading your NAM.

#### Figure 1 NAM Interior components

Figure 1 shows the location of the hardware components in the NAM. We recommend you familiarize yourself with the location of the different components before working with the system. All connections located at the bottom of the NAM are accessed from the cable trough.

### Single Board Computer (SBC)

The Single Board Computer (SBC) is the main computing device of the NAM. All tasks such as answering incoming calls, playing recorded announcements and storing voice messages are controlled by the SBC.

The NAM is equipped with 32 MB of SDRAM. This memory is located in a Dual In-line Memory Module (DIMM) on the SBC. The single 32 MB DIMM is located in memory slot 1. The microprocessor and the clock/calendar battery are also located on the SBC.

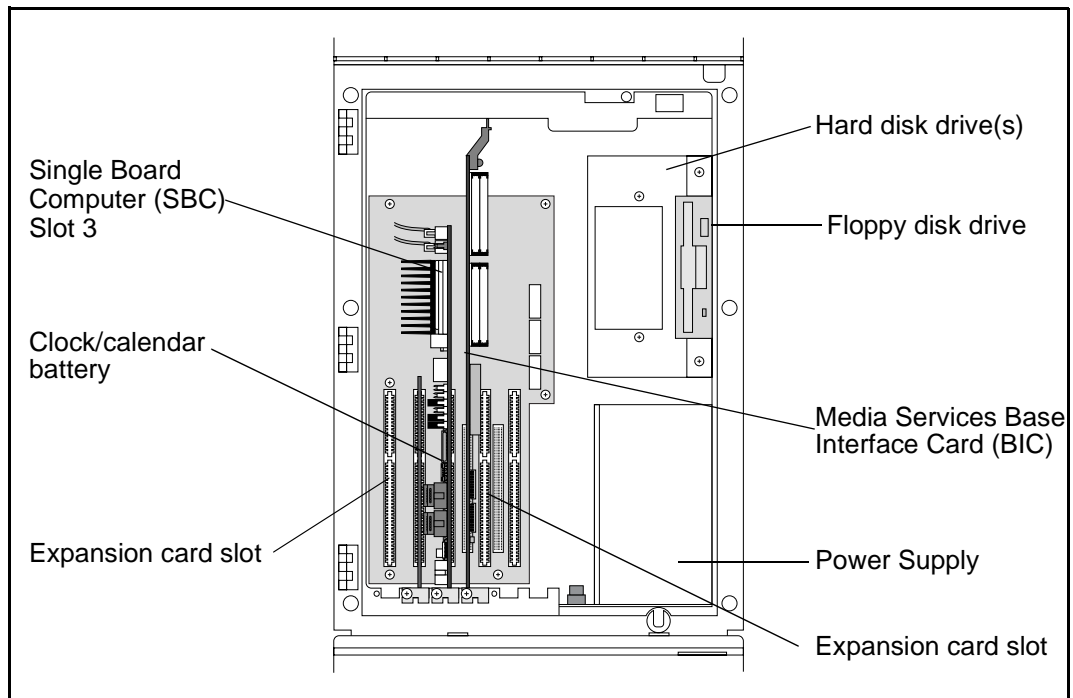

### Media Services Base Interface Card (BIC)

The Media Services Base Interface Card (BIC) is an expansion card installed in the NAM that converts and compresses analog voice signals to digital data for storage on the hard disk. A BIC can have up to 32 Voice Channels. NAM is physically connected to the Norstar KSU by a fiber cable. This allows the NAM to send instructional messages to the KSU and vice versa. Voice Channels on the BIC are enabled through a specific upgrade procedure.

### Hard disk drive

The NAM comes equipped with an IDE 3.5 inch hard disk with a minimum capacity of 200 hours of message storage time. The hard disk drive stores all software, messages, greetings and voice prompts.

**Note:** To ensure your system programming is protected against a hardware failure, you must perform frequent backups of the hard disk drive. For more information about backing up your hard disk, refer to "Backing up the NAM capabilities file" on page 59.

### Floppy disk drive

The floppy disk drive on the NAM is a 3.5 in., 1.44 MB drive. This drive is used to load programs and prompts from floppy disks onto the hard disk. It is also used for backup and restore procedures.

## Connection Ports

External devices, such as a laptop computer or printer, are attached to the NAM through connection ports. The ports are located on the bottom of the NAM and are accessed through the cable trough. Figure 2 shows the location of the different connection ports.

**Note:** Although the NAM is equipped with 2 USB ports, they are not functional for this release. Do not attempt to connect any devices to the USB ports.

**Figure 2** Module external points of connection

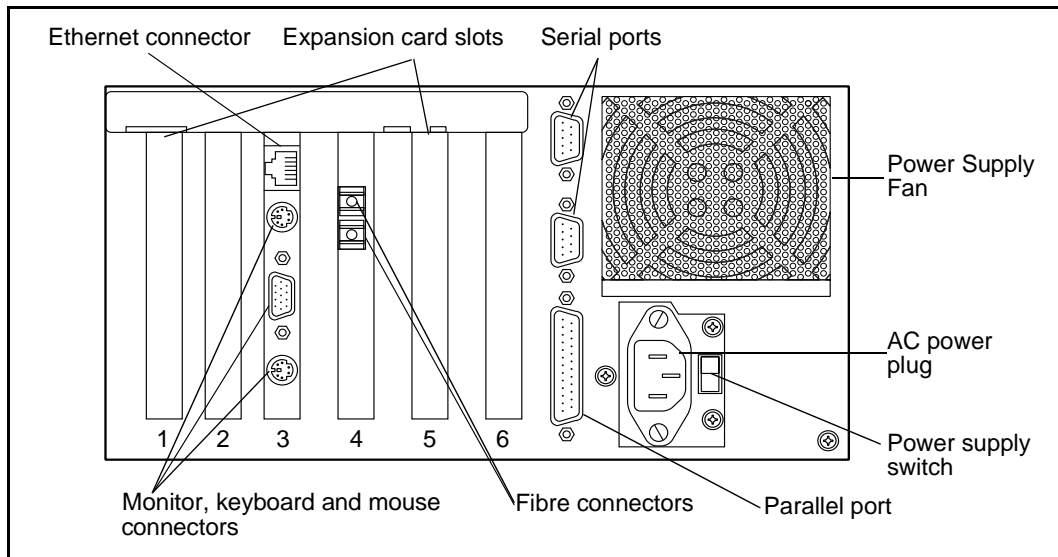

### Serial

The NAM is equipped with two serial ports that support asynchronous RS-232C communication. Each port features a male DB-9 connector and supports all standard baud rates (9600 default). The serial ports are used to connect:

- a laptop computer
- a modem

### Parallel

The NAM is equipped with one parallel printer port that features a female DB-25 connector. This port is used to connect to an optional parallel printer or a CD-ROM drive for software upgrades or CD-ROM drive for software upgrades.

## Optional equipment

Additional equipment can be added to the NAM to enhance its functionality. Additions can include a:

- Modem
- Monitor package
- Printer
- Network Interface Card

### Modem

A modem can be attached to Serial Port A (COM1). The modem is necessary if you intend to perform Administration and Maintenance from a remote location.

### Monitor package

This package is useful for on-site programming and maintenance.

### Printer

A printer can be attached to the parallel port. This printer is used for printing reports and alarms. The NAM supports any EPSON compatible printer.

### Network Interface Card (NIC)

Although the NAM is equipped with an on-board ethernet NIC, a PCI or ISA card can be installed in expansion slot 5 of the NAM. For more information on Nortel recommended NIC cards, refer to the ITAS TIPS Number 108: NIC for NAM.

## About the System software

The NAM comes equipped with system software that allows other Nortel approved applications to operate. In effect, the applications run on top of this software. Figure 3 shows the hierarchy of the applications and system software. System software includes the:

- ACCESS Server Software
- IBM OS/2 Warp™ Operating system

Figure 3 Software hierarchy

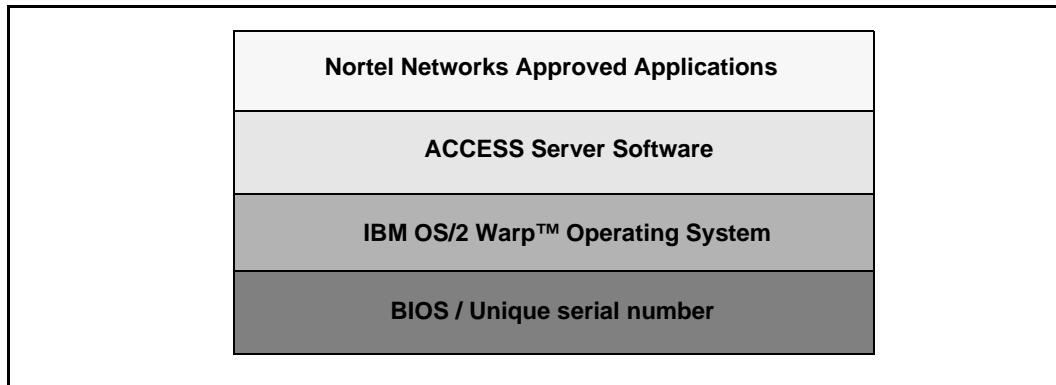

ACCESS is designed to communicate with the Norstar system and provide support for voice, fax, and other applications running on the NAM. This software provides the following services:

- an internal modem for maintenance functions
- routing of all telephony (voice) commands between applications and the BIC
- provision of special features, such as system shutdown
- management of shared resources, such as Voice Channels

NAM uses the multi-tasking IBM OS/2 Warp™ operating system version 4.0 or greater. OS/2 Warp™ and ACCESS are factory installed on the NAM's hard disk drive.

---

## Section II - Installing the Norstar Applications Module (NAM)

- Mounting the NAM on the wall
- Mounting the NAM on a floor mount stand
  - Connecting to the NAM to the KSU

---

# Installing the Norstar Applications Module (NAM)

# 3

## Introduction

This section is intended for the installer of the NAM and describes how the system should be installed and prepared for operation.

## Before you start

Before you start the installation, ensure that you:

- read this guide and understand the installation process
- verify that all conditions are met in the checklists

## Packaging Checklist

Make sure the package you received contains the following items:

- NAM
- the NAM wall mounting bracket
- an AC power cord
- a fiber connector

### Environment Checklist

The installation area must be:

- at least 4 m (approximately 13 feet) from equipment such as copiers, electrical motors and other equipment that could produce electromagnetic, radio frequency and electrostatic interferences
- within 2 m (6.5 ft) of the KSU
- within 1.5 m (approximately 5 feet) of a three-wire grounded electrical outlet
- clean, free of traffic and excess dust, dry and well ventilated
- between 10° and 40° Celsius (approximately 50° to 104° Fahrenheit)
- between 8% and 80% non-condensing relative humidity
- a wall area approximately 1 m square (approximately 10 sq feet)
- a minimum of 16 cm (approximately 6 inches) from a corner wall or other component
- a minimum of 46 cm (approximately 18 inches) from the floor

**Note:** The distance from the floor to the installation area should be enough to prevent water damage.

The NAM does not require a dedicated circuit. **Do not** connect the NAM to an AC outlet on a circuit that is likely to be overloaded or used by large office equipment or power tools.

### Special parts and equipment

For the installation, you need the following equipment:

- Phillips #2 screwdriver
- power drill
- flat blade screwdriver
- antistatic grounding strap
- four #10 X 2.5 cm (#10 X 1 inch) round head wood screws
- plywood backboard 2 cm (3/4 inch) thick
- surge protector (recommended)

### Other documentation

In addition to the documentation included in the package you received, the *Norstar Installation Guide that came with your Norstar KSU* may also be necessary.

## Installation overview

Installing a NAM involves the following:

- power supply switch setting (if required)
- mounting the unit on the wall or floor mount stand
- connecting the NAM to the Norstar KSU
- connecting the power cord

### Changing the power supply voltage

The power supply on the NAM is set at the factory to operate at 115 volts. If you plan to use 115 volts to power the NAM, do not change the voltage switch. If you plan to use 230 volts to power the NAM, you **must** change the power supply voltage setting before mounting the unit on the wall. Refer to "Changing the power supply voltage" on page 77.

For more information, refer to "Installing and replacing the Single Board Computer (SBC)" on page 79.

### Mounting the NAM on the wall



**Caution**

The NAM contains fragile electronic components. Do not drop or bump the module. The NAM weighs 13.6 kg (30 lbs). You must fasten the back of the module to the backboard to fully support the weight of the NAM.

1. Install the 2 cm inch plywood backboard on the wall.
2. Position NAM mounting bracket on the backboard. Place the smooth side flush against the backboard, with the screw holes near the top. Ensure the bracket is level.
3. Fasten the bracket to the backboard. Use two #10 X 2.5 cm (#10 X 1 inch) round head wood screws through the inner pair of holes.

**Figure 4 The NAM mounting bracket**

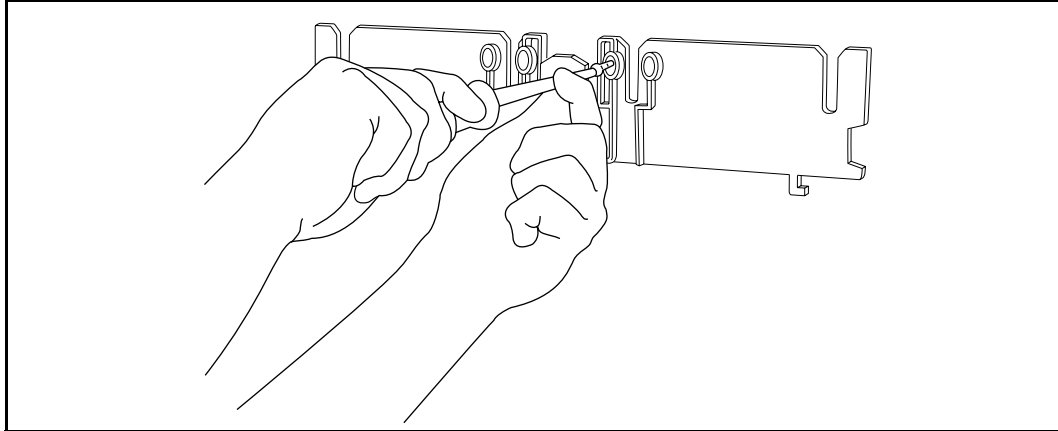

4. Slide the NAM down onto the center bracket flange. Line up the notches on the far sides of the bracket to the flanges on the NAM.
5. Open the front cable trough door. Fasten the bottom of the NAM to the backboard. Use two #10 X 2.5 cm (#10 X 1 inch) round head wood screws through the screw holes on each side of the cable trough.

**Figure 5 Hanging the NAM**

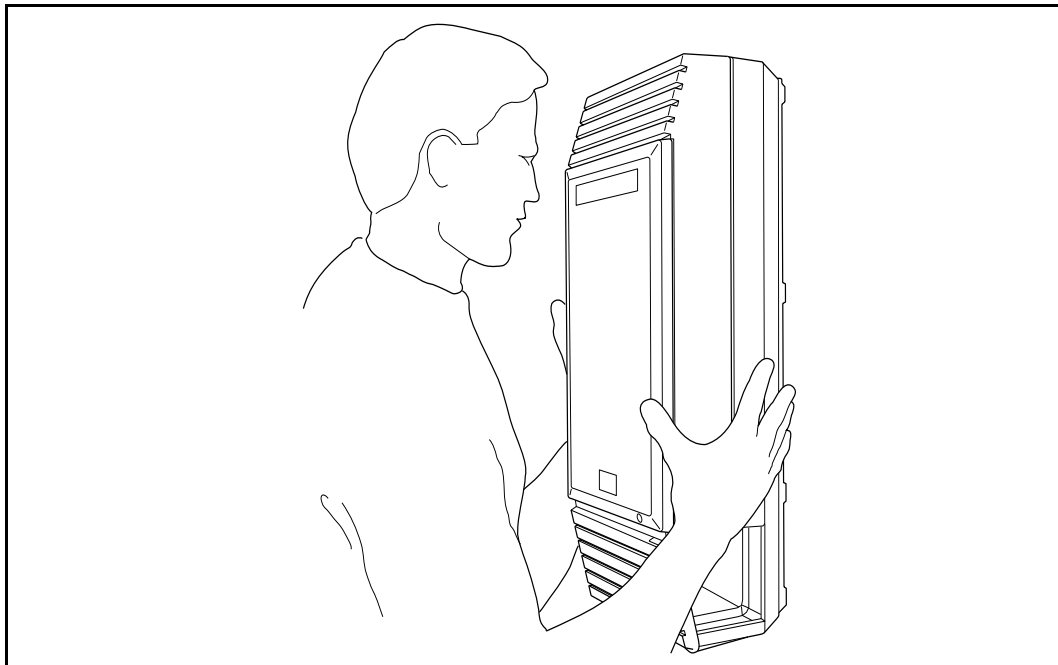

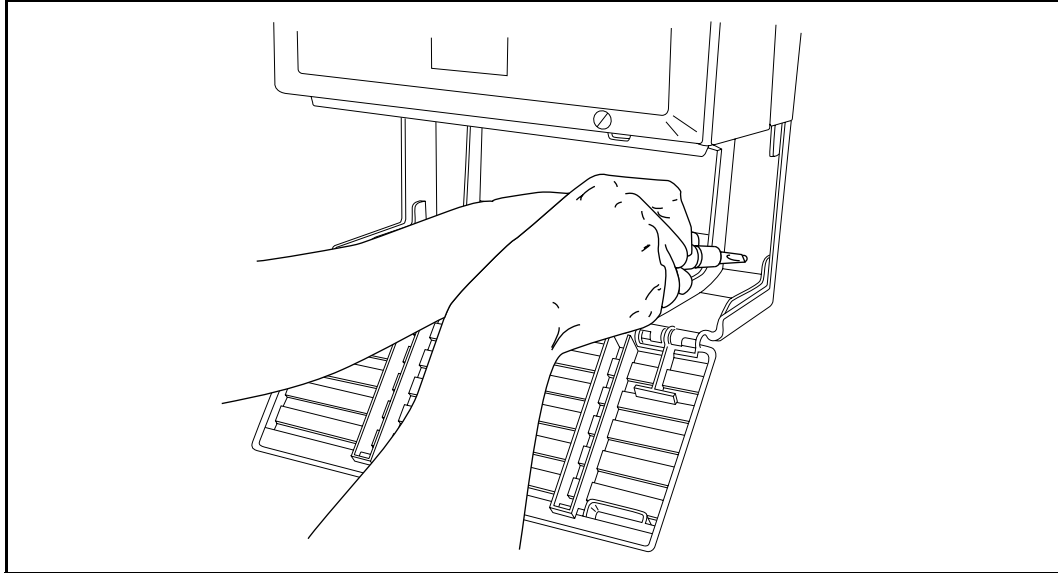
**Figure 6 Installing the cable trough screws**

## Floor mount stand

The floor mount stand is an alternative to wall-mounting the NAM. The stand allows the module to sit on any horizontal surface. The floor mount stand is useful when you are attaching a monitor and keyboard to the NAM and want it situated near a desk.

**CAUTION**

Refer to "Environment Checklist" for acceptable environmental conditions before selecting a location for the NAM.

## Assembling the floor mount stand

Before you can attach the floor mount stand to the NAM, you must first assemble the stand.

To assemble the floor mount stand:

1. Align the two halves of the floor mount stand back to back.
2. Using the four screws provided, fasten the two sides together. Refer to Figure 7 for an illustration of an assembled floor mount stand. You must use all four screws.

### Attaching the floor mount stand to the NAM

To fasten the floor mount stand to the NAM:

1. Rest the module on a tabletop with the door facing down. The cable trough should hang over the edge of the table. If a table is not available, rest the module on the floor mount stand carton.
2. Remove the top screws at the back of the module. Leave the washers in place. You will need them if you want to place the module on the wall again.
3. Rest the floor mount stand on top of the module, aligning the stand into the groove on the back of the module. The longer of the two feet on the stand must be pointing down, towards the front of the module.
4. Align the four screw holes between the module and the stand.
5. Fasten the screws into the module.



**Caution**

Only use the screws that came with the floor mount stand or are on the back of the unit. **Do not substitute screws.** Substitute screws can damage the module.

Figure 7 Fastening the floor mount stand to the module

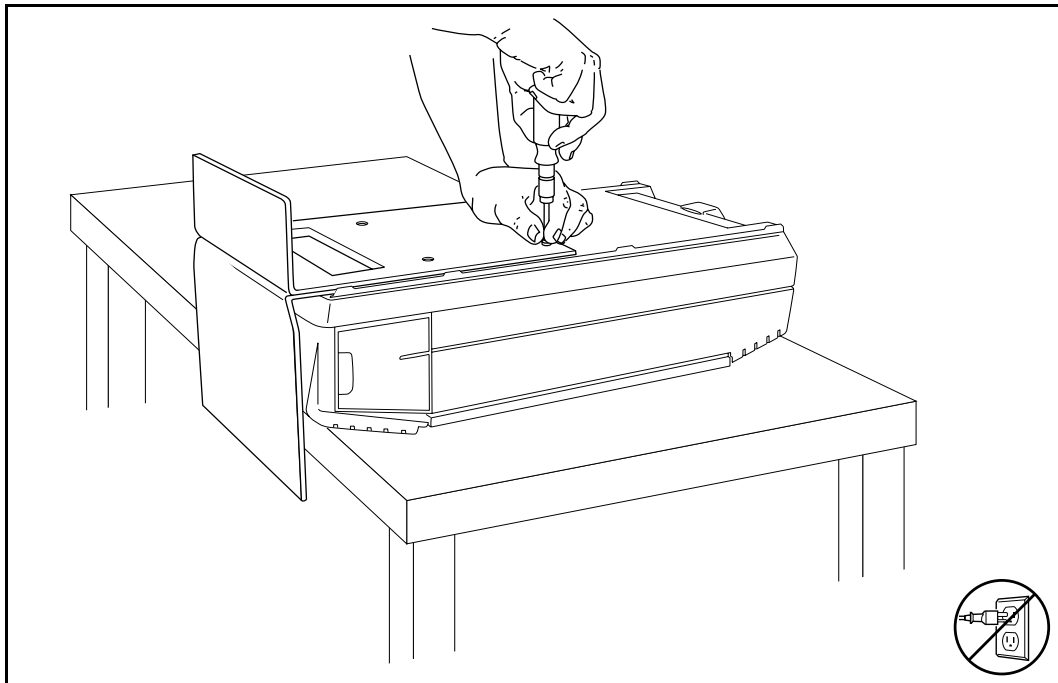

6. Put the module in the location you want.

7. Reconnect the cables

**Note:** You can run the cables through the ends of the cable trough or through the back.

8. Plug the power cord into the AC outlet. If you are installing the monitor package, do not plug the NAM in until the installation is complete.

### Installing the end-caps

To install the end-caps:

1. Make sure the front cable trough door is open.
2. Place the bottom of the end-cap into the slot in the bottom of the trough. There are two end-caps, one for the left side, and one for the right side of the cable trough.
3. Slide the end-cap straight back to the end of the slot.

### Connecting the NAM to the KSU

A NAM can only be connected to a Norstar KSU that supports fiber connections. To verify the compatibility of your KSU, refer to Table 1.

**Table 1 KSU fiber connection compatibility**

KSU Version	SP Software Number
Modular ICS Release 1 - T1	All version numbers are compatible
Modular ICS Release 1 - Centrex	All version numbers are compatible
USA-MICS-XL 1.0	All version numbers are compatible
USA-MICS-XC 1.0	All version numbers are compatible
CDA-MICS-XC 1.0	All version numbers are compatible
USA-MICS-XC 1.1	All version numbers are compatible
CDA-MICS-XC 1.1	All version numbers are compatible
NA-MICS-DR 1.1	All version numbers are compatible
NA-MICS-DR 2.0	All version numbers are compatible
NA-MICS-DR 4.0	All version numbers are compatible
NA-MICS-DR 4.1	All version numbers are compatible

**Note:** If the Norstar KSU does not support fiber connections, a DS30/Station Port Adapter must be installed. For more information, talk to your service representative.

### Fiber cable precautions

To avoid damage that can affect the signal transmitted by the fiber cable, observe the following guidelines when connecting the NAM to the KSU:

- Coil excess fiber on the spool provided for the installation.
- Secure the fiber cable spool in the KSU cable trough.
- Ensure the bends in the cable are no tighter than 100 mm (4 in.) in diameter.
- When using cable ties, bundle fiber cable loosely.
- Avoid excessive pulling, compression or impact.
- Do not grasp the fiber cable or the clasp where the cable joins the plug, when connecting or disconnecting a fiber cable plug to or from a port.
- Do not leave the fiber cable in an environment with excessively high temperature (for example, on top of radiators).

**Note:** Before you connect the NAM to the KSU, ensure the NAM is installed within 2 m (6.5 ft) of the KSU. 2 m (6.5 ft) is the maximum length of the fiber cable.

To connect the NAM to the KSU:

1. Ensure there is one expansion port capable of supporting a Station Module or a Trunk Module available at the KSU. For instructions about installing an Expansion Cartridge, refer to the *Norstar Installation Guide* that came with the Norstar KSU.

Figure 8 Connecting the KSU to the NAM

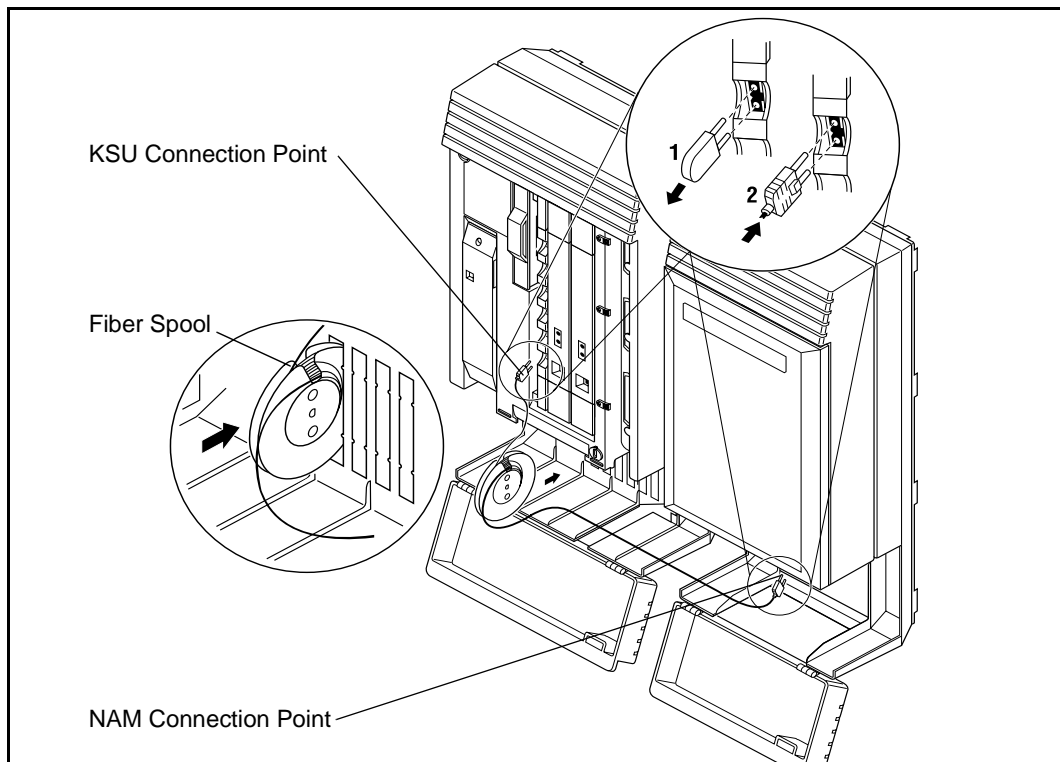

2. Connect one end of the fiber connector in an available expansion port on the KSU. The fiber connector is keyed and can only be inserted one way. Ensure the connector snaps into place.
3. Locate the BIC fiber connection point on the bottom of the NAM. The BIC will be located in slot 4. Remove the two rubber protectors from the fiber connection points on the BIC. For the location of the NAM connection points, refer to Figure 8 on page 28.

**Figure 9 Fiber Connection Points - Bottom view**

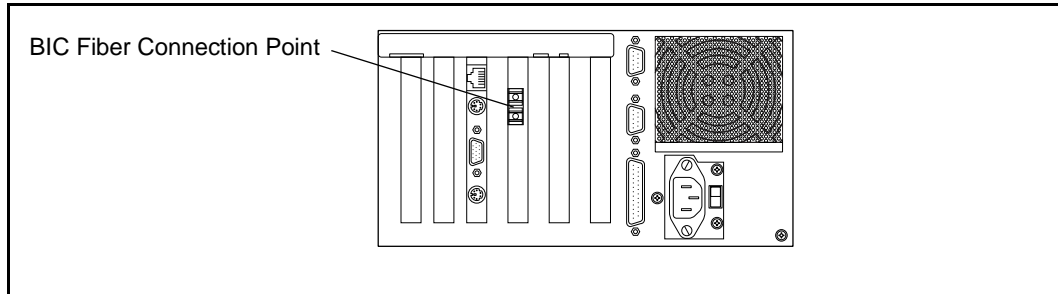

4. Connect the other end of the fiber connector into the BIC. The fiber connector is keyed and can only be inserted one way. Ensure the connector snaps into place.
5. Ensure all the excess fiber cable is on the spool provided and the spool is in the KSU cable trough. All the cabling should be run through the bottom or sides of the cable trough.



**CAUTION**

Do not place any other components, such as a power bar, into the NAM cable trough. Obstructions in the cable trough restrict a cooling air flow and may cause the unit to overheat.

## Starting the NAM

Read the power supply warning label, covering the AC power plug, before starting NAM.

1. Plug in the NAM. Wait until the self-diagnostics are completed. This can take up to five minutes.



**CAUTION**

The power supply default setting is 115 volts. For more information about changing the power supply voltage setting, refer to "Installing and replacing the Single Board Computer (SBC)" on page 79.

---

## Section III - Norstar Applications Module (NAM) Hardware Upgrades and Replacements

- Preparing for the upgrade
- Installing the clock/calendar battery
- Installing and upgrading the Digital Fax Card (DFC)
- Installing and upgrading the Media Services Base Interface Card (BIC)
  - Installing a new floppy disk drive
  - Installing and upgrading the hard disk drive
    - Adding and replacing memory
  - Adding or removing a monitor, keyboard and mouse
    - Adding the NAM to a network
  - Changing the power supply voltage
- Installing or replacing the Single Board Computer (SBC)

## Overview

Hardware upgrades to the Norstar Applications Module (NAM) are required when additional capacity or functionality is needed. This section describes upgrade or replacement procedures for the following:

- clock/calendar battery
- Digital Fax Card (DFC)\*
- Media Services Base Interface Card (BIC)
- floppy disk drive
- hard disk drive
- memory
- monitor, keyboard and mouse
- Single Board Computer (SBC)

\*Only on systems with applications that support FAX functionality. For example, Norstar Voice Mail. Refer to Figure 1 on page 13 for the location of the NAM interior components.

**Note:** The power supply is not a field replaceable part.

## Special tools

Before you begin replacing or upgrading the components, ensure you have the following equipment:

- #2 Phillips head screwdriver that has a blade 3.5 in. long
- 3/16 in. slot screwdriver
- an antistatic grounding strap



### CAUTION

You must wear an antistatic grounding strap at all times when handling electronic components. Failure to do so may result in damage to the equipment.

## Shutting down the NAM

This option allows the installer to “gently” shutdown the NAM. OS/2 Warp™ requires a slow shutdown to guarantee the integrity of the file system.

Three shutdown options are available: Graceful, Quick and Immediate. The Graceful option allows an application to terminate all existing calls before shutting down. The Quick option only allows 45 seconds for an application to terminate before shutdown, and the Immediate option only allows 15 seconds.

When you are shutting down the NAM you will usually use the Graceful option. However, if the system is not responding to the command, you can speed up the process by changing the option to a Quick shutdown. After 45 seconds a Quick shutdown is performed.

To shutdown the NAM:

1. Press     .

2. Enter the ACCESS password.

**Note:** The default password is ACCESS2 (2223772).

3. Press NEXT .

4. Press SHOW .

5. Press GRACE .

**Note:** Press NEXT to change the shutdown option to QUICK (Quick) or IMMD (Immediate).

Shutdown Graceful  
YES NO

6. Press **YES**.

**Note:** Press **NO** if you want to stop the shutdown.

The NAM issues a series of tones descending in pitch when the shutdown is complete. Wait for the tones before you unplug the NAM.

## Accessing the inside of the NAM

You must unplug the NAM before you install or remove any components. The NAM components are accessed by removing the front cover or plastic case. Access to external connections is made through the cable trough. Figure 10 shows the different access points on the module.

Figure 10 Parts involved while accessing the inside of the module

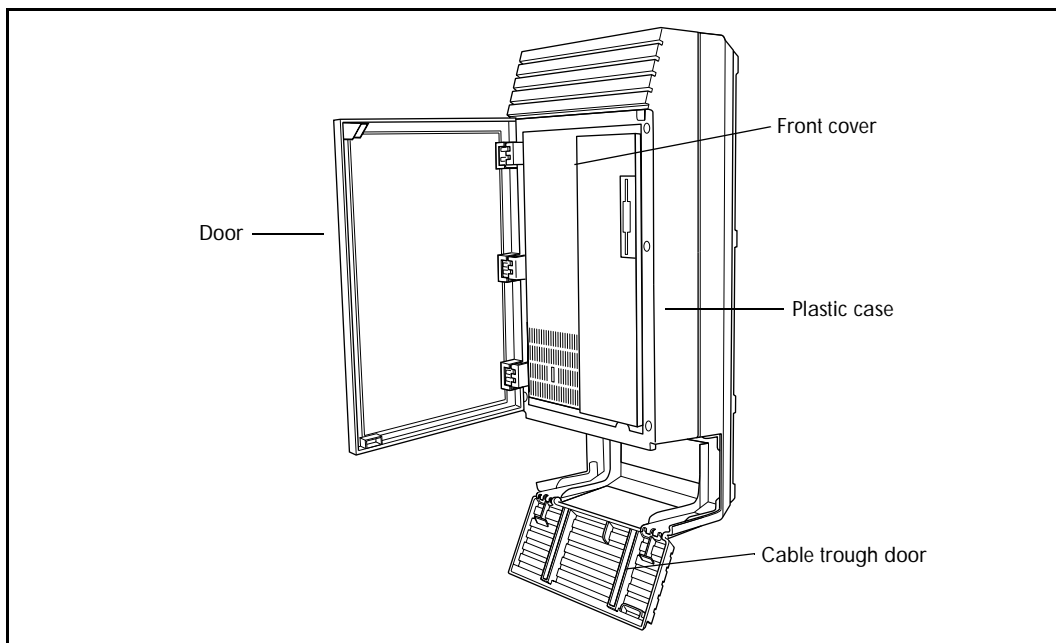

The front cover must be removed when you need to access all internal components.

**Note:** You must remove both the front cover and plastic case when you need to replace the floppy disk drive.



### **WARNING**

The plastic door is part of the fire enclosure system. This door is required to meet safety requirements. It must be closed upon completion of each installation or repair.

## Removing the front cover

For most component upgrades or replacements you must remove the front cover. The front cover protects the components from dust and assists in evenly distributing air flow from the fans.

To remove the front cover:

1. Shutdown the NAM. For more information, refer to "Shutting down the NAM" on page 34.
2. Remove the NAM power cord from the AC outlet.
3. Ground yourself by attaching one end of the grounding strap to your wrist and the other end to a grounded metal surface.
4. Open the module door. The door may be locked. To unlock the door, use a screwdriver to turn the lock in the bottom-right corner of the door. Turn the lock 90° counterclockwise until the screwdriver slot is vertical.
5. Remove the two screws holding the front cover to the module. The screws are located along the top of the front cover.
6. Slide the front cover out from the module.

Figure 11 Removing the front cover

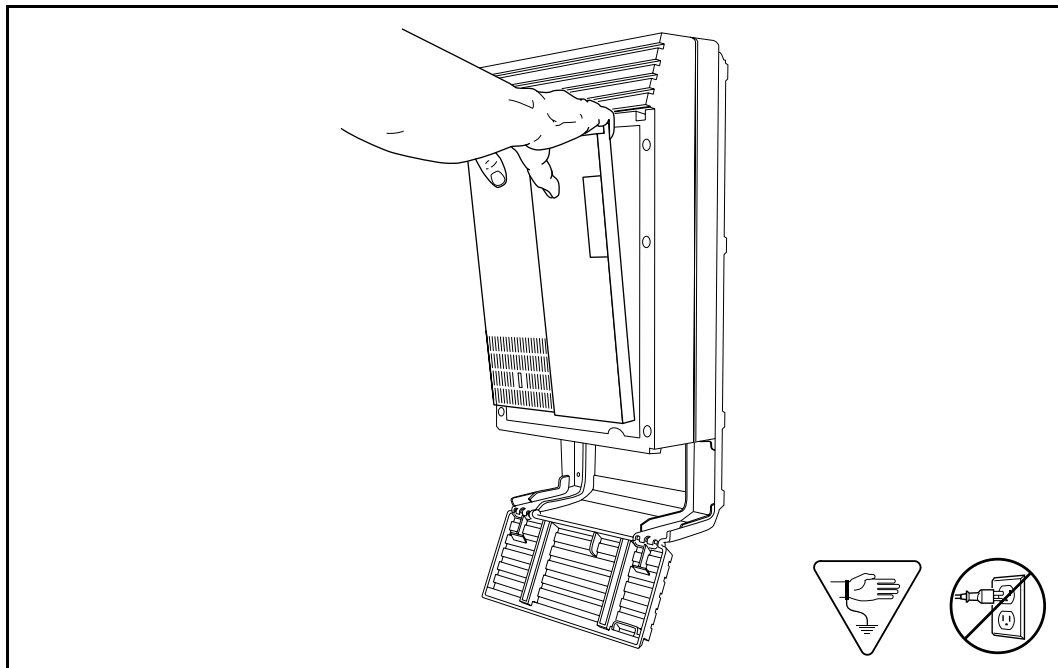

To replace the front cover:

1. Insert the tongues on the bottom of the front cover into the module slots.
2. Fasten the two screws holding the front cover to the module.
3. Close the module door. To lock the door, turn the lock 90° clockwise until the screwdriver slot is horizontal.
4. Plug the power cord into the AC outlet.

### Opening the cable trough

The cable trough provides access to the external connections. You must open the cable trough when you want to access the Network Interface Card (NIC) connector, serial ports, parallel port, video connector and the mouse and keyboard ports.

To open the cable trough door, grasp the slot in the upper right corner of the door and pull down. The door will swing down.

To close the front cable trough door, swing the door up until the two tongues on the door fit snugly into the case.

### Removing the plastic case

Before you remove the plastic case, you must ensure that the two screws in the cable trough that secure the case to the wall are in place.

To remove the plastic case:

1. Shutdown the NAM. For more information, refer to "Shutting down the NAM" on page 34.
2. Open the cable trough.
3. Remove the NAM power cord from the AC outlet.
4. Remove the front door by unclipping it from its three hinges.
5. Remove the six screws mounted around the front edge of the plastic case.

**Note:** The screws are deeply recessed in the plastic case.

6. Pull the plastic case towards you and away from the module.

To replace the plastic enclosure:

1. Place the plastic enclosure on the module and fasten its six screws to the module.
2. Replace the door by clipping it to its hinges.
3. Plug the power cord into the AC outlet.
4. Close the cable trough door.

## Overview

The clock/calendar battery is responsible for keeping BIOS information current if the power to the module goes down. The BIOS contains information such as the unique serial number of the Norstar Applications Module (NAM) system. The battery must be replaced with a 3 V, 170 mAh, lithium coin cell.

**WARNING**

If you do not replace the battery with a 3 V, 170 mAh, lithium coin cell battery, there is a danger of explosion.

## Removing and replacing the battery

To remove the battery:

1. Shutdown the NAM. For more information, refer to "Shutting down the NAM" on page 34.
2. Remove the NAM power cord from the AC outlet.
3. Ground yourself by attaching one end of the grounding strap to your wrist and the other end to a grounded metal surface.
4. Remove the front cover. Refer to "Accessing the inside of the NAM" on page 35.
5. Using your finger, gently lift the metal clamps that hold the battery in the socket. The socket is located on the SBC.
6. For the location of the battery, refer to "Removing the battery" on page 40.
7. If the battery doesn't immediately fall out of the socket, gently wiggle the SBC. This will cause the battery to drop out of the socket into your hand.

**CAUTION**

Do not use any type of tool to remove the battery.

Figure 12 Removing the battery

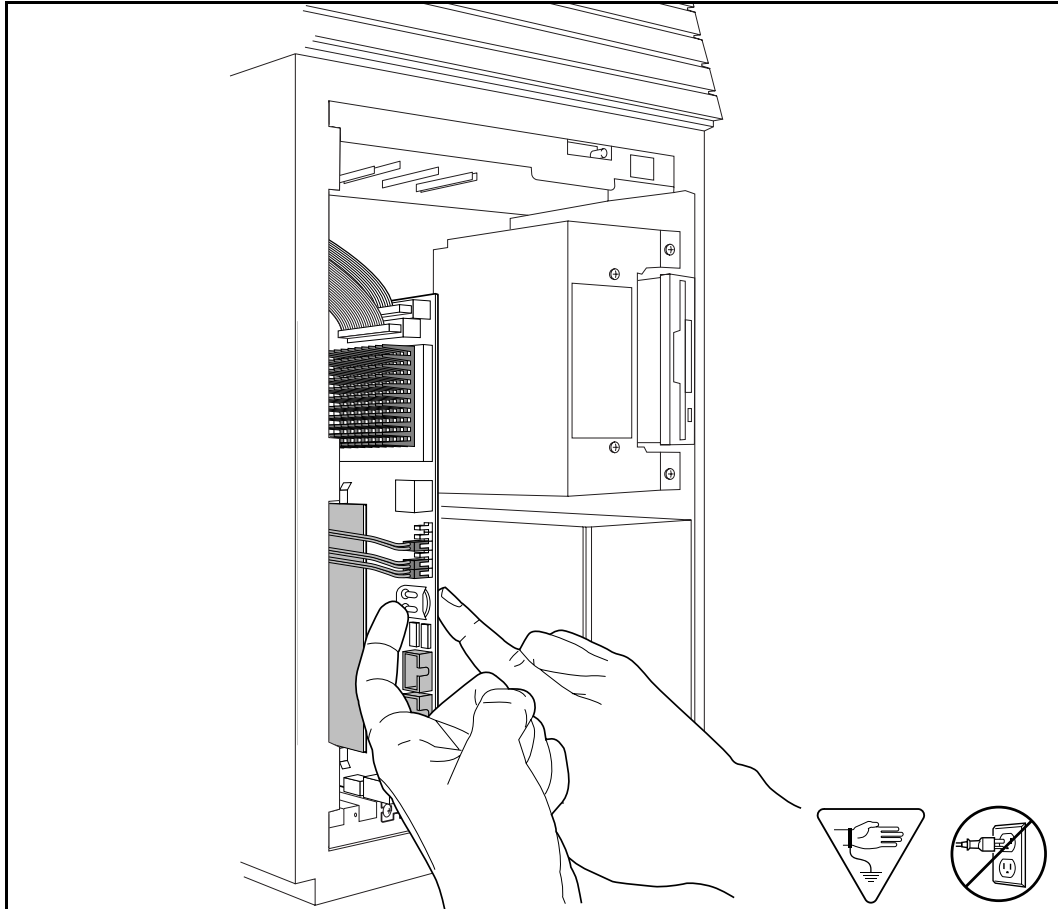

To install a new battery:

1. Slide the battery under the metal clip until the battery snaps into the socket. Ensure the battery is completely seated in the socket. The positive (+) side of the battery faces upward.



**WARNING**

There is a danger of explosion if the battery is incorrectly replaced. You must replace the battery with a 3 V, 170 mAh, lithium coin cell battery.

2. Replace the front cover.
3. Close the module door. To lock the door, turn the lock 90° clockwise until the screwdriver slot is horizontal.
4. Plug the power cord into the AC outlet.

## Overview

A Digital Fax Card (DFC) can only be added to a Norstar Applications Module (NAM) that is equipped with software that supports fax functionality. The DFC is installed in Expansion Bus slot 1 of the NAM. A DFC can support up to four Fax Channels.

The DFC uses the Voice Channels on the BIC to connect the Fax Channels to fax machines or callers.

**Note:** When Norstar Voice Mail FAX is using a Voice Channel to connect to the fax machine or a caller, that Voice Channel cannot be used by other users until the fax function is complete.

Only one DFC can be installed in the NAM. A Media Services Bus Expansion Card (BEC) Type A must be installed on the BIC before connecting the DFC.

A BEC is a daughterboard that is installed to provide the BIC with the ability to connect to a DFC. The DFC is connected to the BEC daughterboard by a PCM Expansion Bus (PEB) cable. The PEB Cable allows the DFC to share the Voice Channels connected to the Norstar KSU.

The following section provides step-by-step instructions for the installation of a DFC, BEC and PEB cable.

Figure 13 Digital Fax Card

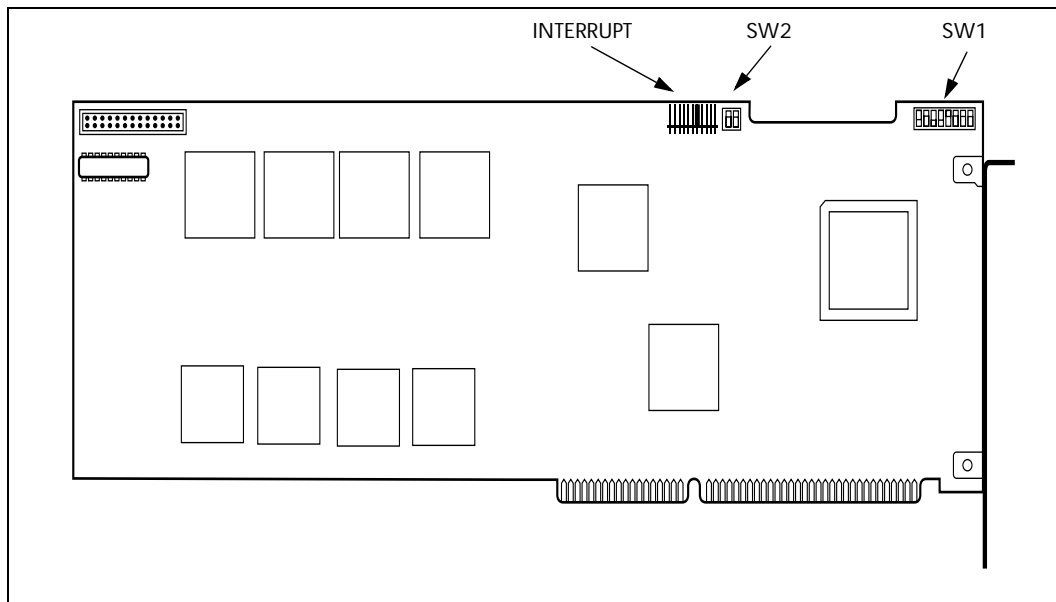

## Precautions

Before installing or upgrading a DFC, you **MUST** take the following precautions:

- **Unplug the NAM power cord.** The NAM power supply contains high voltage. If you do not unplug the power cord you may severely injure yourself. Also, if cards are installed or removed from the NAM before the power cord is unplugged, the cards and/or the NAM may be damaged.
- **Wear a ground strap.** Static electricity can damage the components on the cards and the NAM. Always wear a properly grounded antistatic strap while handling the DFC, BIC, BEC or any other component of the NAM.

## Installing the DFC

1. Shutdown the NAM. For more information, refer to "Shutting down the NAM" on page 34.
2. Remove the NAM power cord from the AC outlet.
3. Open the front cover of the NAM. Refer to "Accessing the inside of the NAM" on page 35.
4. Ground yourself by attaching one end of the grounding strap to your wrist and the other end to a grounded metal surface.
5. Locate slot 1 on the expansion bus. Remove the slot cover screw and the metal slot cover from the slot.
6. Switch SW1 should be set according to the following table:

P	n	8	o	7	i	6	i	5	s	4	o	3	2	1
State		off		on		off		off		on		on		on

7. Switch SW2 should be set according to the following table:

P	n	2	o	l	i	t	i	s	o
State		on		on					

8. Ensure there is a jumper on position 10 of the INTERRUPT.

**Note:** The settings are the default values and should be set properly when the board is received. Refer to Figure 13 on page 41 for the location of the jumper posts SW 1 and switch SW2.

9. Carefully hold the DFC along the top. Insert the card by aligning it between the groove on the top of the NAM and the slot opening at the bottom of the NAM.
10. Push the DFC straight in until it is snugly in place. Ensure the edge connector is firmly inserted into the backplane socket.

Figure 14 Inserting the DFC

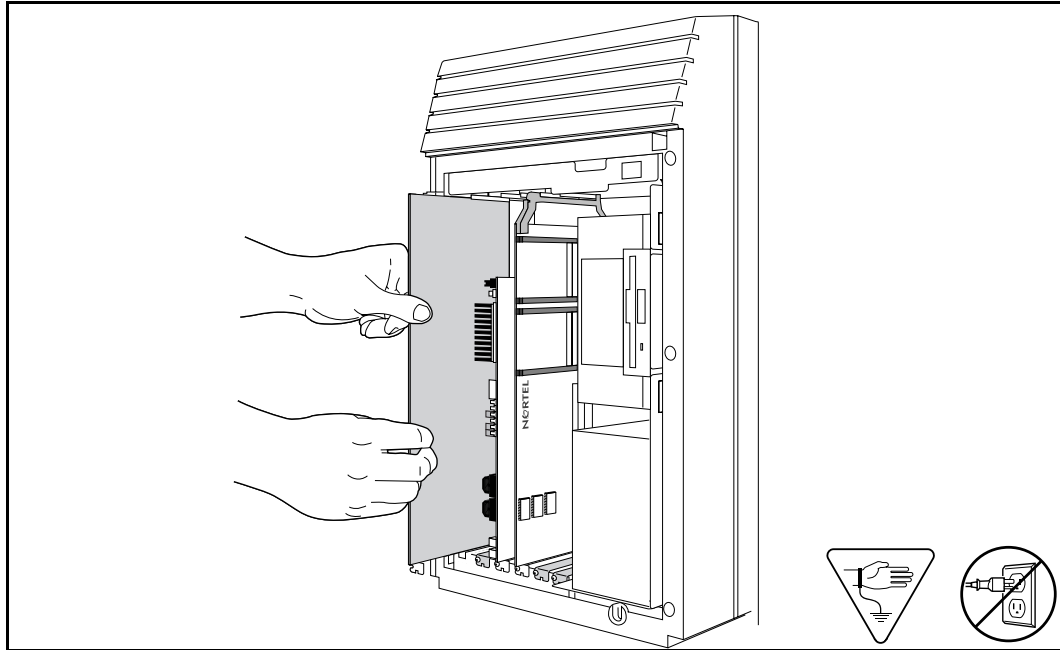

11. Fasten the slot cover screw in the DFC slot cover.
12. Proceed to step 1 of Installing the Media Services Bus Expansion Card (BEC) on the BIC.

## Installing the Media Services Bus Expansion Card (BEC) on the BIC

A Media Services Bus Expansion Card (BEC) Type A is a daughterboard that is installed on the BIC provides the BIC with the ability to connect to a Digital Fax Card (DFC). The DFC allows the NAM fax capability. The DFC is connected to the BEC daughterboard by a PCM Expansion Bus (PEB) cable. The PEB Cable allows the DFC to share the Voice Channels connected to the Norstar KSU.

Before you begin the installation, you must have #2 Phillips screwdriver.

To install the BEC:

1. Shutdown the module. For more information, refer to "Shutting down the NAM" on page 34.
2. Remove the NAM power cord from the AC outlet.
3. Ground yourself by attaching one end of the grounding strap to your wrist and the other end to a grounded metal surface.
4. Remove the NAM front cover. Refer to "Accessing the inside of the NAM" on page 35.
5. Remove the BIC from the NAM. Refer to "Removing the BIC" on page 54.
6. Place the BIC on a flat surface, with the components facing up. Refer to Figure 16 on page 45.



**Caution**

Failure to place the BIC on a flat surface may result in serious damage to the BIC. While the BIC is out of the NAM, be careful not to slide or catch the back of the BIC, this may cause damage to the pins on the back of the board.

7. Unpack the BEC from the shipping container. Make sure you the BEC is not damaged.
8. Unpack the small plastic bag from the shipping container. Make sure you have two screws and two jumpers.
9. Locate JP1 and JP2 on the BEC. JP1 and JP2 are located next to the PEB connector.
10. Remove the two jumpers from the small plastic bag. Install the two jumpers in an "open" position on the bottom pin of JP1 and JP2. For the jumper to be in the "open" position, the outside half of each jumper does not cover a pin. Refer to Figure 15 for the jumper positions.

Figure 15 BEC jumper position

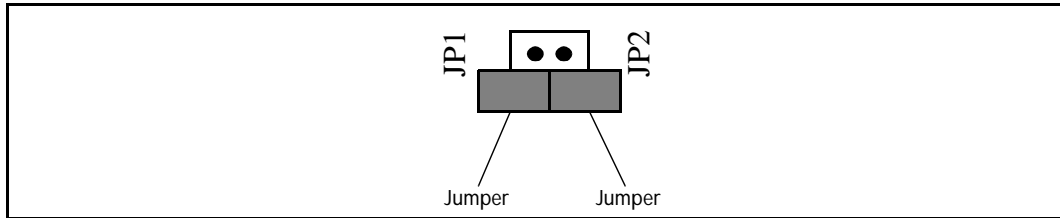

11. Unpack the BEC daughterboard from the shipping container and antistatic bag. The BIC is equipped with two posts at the bottom of the board for connection of the BEC daughterboard. Handle the BEC daughterboard by its edges at all times. Do not touch any card components. Make sure you have the two screws that came with the BEC daughterboard

Figure 16 BIC connection points

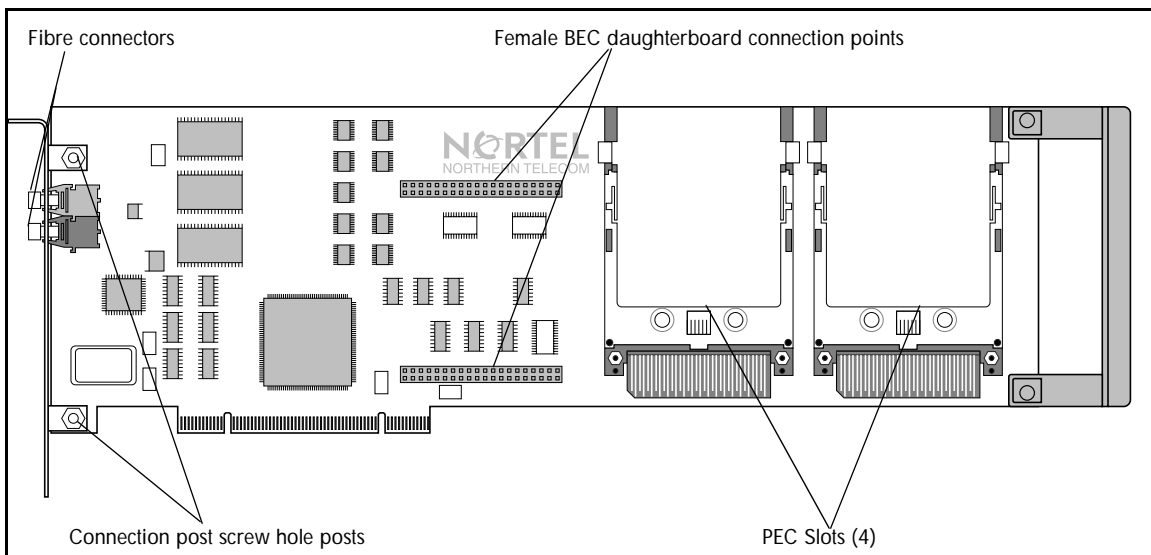

12. Lightly press the BEC daughterboard down onto the female BEC daughterboard connectors on the BIC. The BIC connection screw hole posts should be flush with the BEC daughterboard screw holes. For the location of the BIC and BEC daughterboard connection points, refer to Figure 16.
13. Before pressing the BEC daughterboard completely down, ensure the male BEC daughterboard connectors line up with the female BEC daughterboard connection points on the BIC.
14. Fasten the BEC daughterboard to the BIC connection screw hole posts using the two screws provided. For the location of the BIC and BEC daughterboard connection points, refer to Figure 16 on page 45.
15. Insert the BIC back into the NAM. Refer to "Re-installing the BIC" on page 54.
16. Replace the front cover.
17. Plug the power cord into the AC outlet.

## Connecting the DFC to the BIC with the PEB Cable

There are no fiber connections to the DFC. The DFC uses the Voice Channels on the BIC to connect the fax ports to fax machines or callers.

Only one DFC can be installed in the NAM. The DFC connects to the BEC daughterboard attached to the BIC through the PCM Expansion Bus (PEB) cable. The PEB cable connects the DFC to the BIC to share the Channels connected to the Norstar KSU.

**Note:** The BIC must have a BEC daughterboard installed before it can be connected to the DFC. For instructions on installing the BEC daughterboard, refer to "Installing the Media Services Bus Expansion Card (BEC) on the BIC" on page 44.

Figure 17 on page 46 shows an example of how the PEB cable is installed. The DFC is at the left end of the PEB "chain" in slot 1 and the BIC is at the other end of the chain in slot 4. The three extra connectors on the PEB cable remain empty.

You must use the PEB cable that is provided in the BEC shipping container. The PEB cable is pre-folded for correct installation.

**Figure 17** Connecting the BIC to the DFC

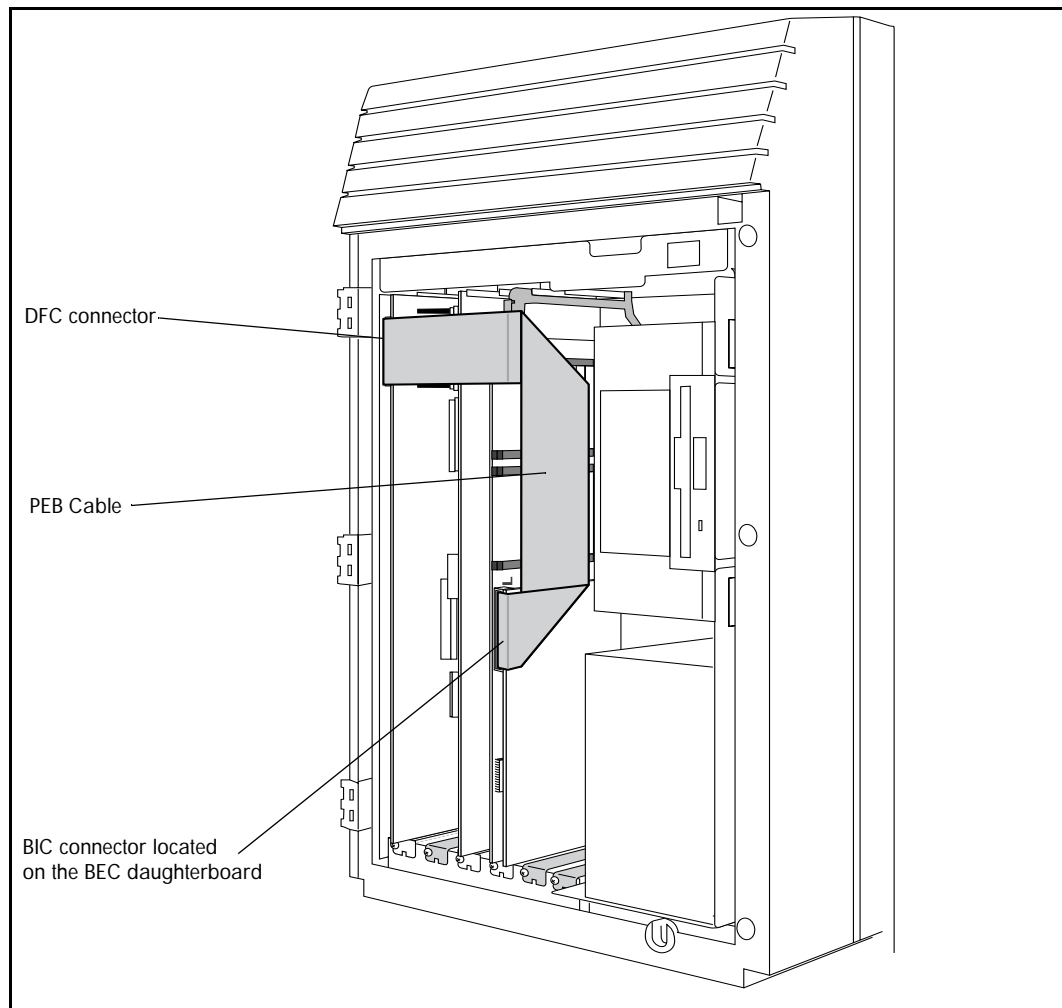

**WARNING**

The microprocessor heat sink may be hot. Pay careful attention not to touch the heat sink when installing the PEB cable.

To connect the BIC to the DFC with the PEB cable:

1. Connect one end of the PEB cable to the PEB socket on the DFC. The PEB cable is keyed and can only be installed one way. You must also ensure the Pin 1 indicator (colored stripe) is on the edge furthest away from the top of the module.

**Figure 18** Installing the PEB Cable on the DFC

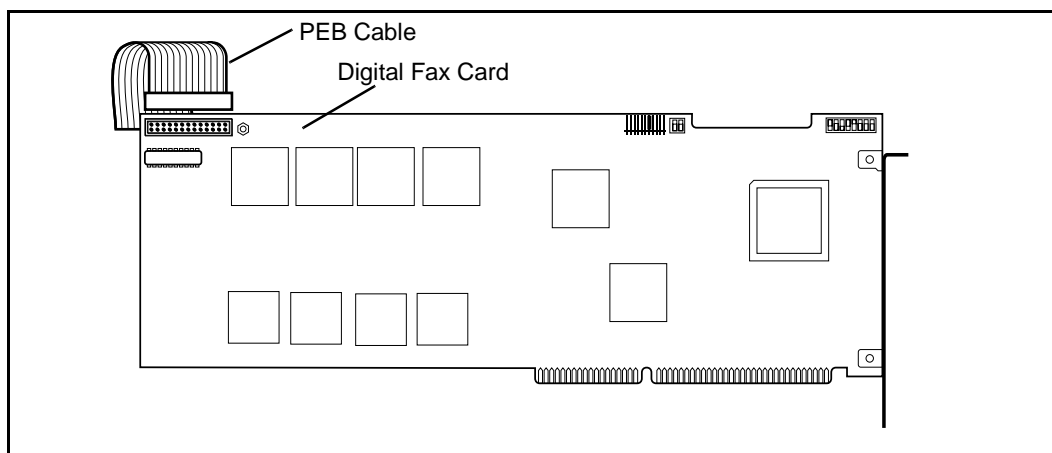

2. Connect the last connector on the PEB cable to the BIC. The remaining connectors on the PEB cable can remain empty and can be folded and gently pushed flat against the backplane.
3. Replace the front cover. Insert the tongues on the bottom of the front cover into the module slots.
4. Fasten the two screws holding the front cover to the module.
5. Close the module door. To lock the door, turn the lock 90° clockwise until the screwdriver slot is horizontal.
6. Plug the power cord into the AC outlet.

## Removing fax functionality from the System

These steps are to be used **only** if you are removing the DFC and fax functionality from a NAM that is equipped with Norstar Voice Mail. If you are replacing the DFC, refer to "Installing the DFC" on page 42.

To remove fax functionality from the NAM:

1. Shutdown the module. For more information, refer to "Shutting down the NAM" on page 34.
2. Remove the NAM power cord from the AC outlet.
3. Ground yourself by attaching one end of the grounding strap to your wrist and the other end to a grounded metal surface.
4. Remove the NAM front cover. Refer to "Removing the front cover" on page 36.
5. Disconnect the PEB Cable from the BEC.
6. Remove the BIC from the NAM. Refer to "Removing the BIC" on page 54.
7. Place the BIC on a flat surface, with the components facing up. Refer to Figure 16 on page 45.



### **Caution**

Failure to place the BIC on a flat surface may result in serious damage to the BIC. While the BIC is out of the NAM, be careful not to slide or catch the back of the BIC, this may cause damage to the pins on the back of the board.

8. Remove the screws holding the BEC daughterboard to the BIC. For the location of the BIC and BEC daughterboard connection points, refer to Figure 16 on page 45.
9. Lightly pull the BEC daughterboard off of the female BEC daughterboard connectors located on the BIC.
10. Locate the DFC in slot 1.
11. Remove the slot cover screw.
12. Disconnect the PEB Cable from the DFC.
13. Carefully hold the DFC with both hands along the top. Lift the DFC straight up and out from the module. Sometimes the DFC is tightly seated and hard to remove. You may need to wiggle it out with a slight rocking motion.

14. Close the module door. To lock the door, turn the lock 90° clockwise until the screwdriver slot is horizontal.
15. Plug the power cord into the AC outlet.

---

# Installing and upgrading the Media Services Base Interface Card (BIC)

## Overview

Each Norstar Applications Module (NAM) is equipped with a Media Services Base Interface Card (BIC) and a specific number of Voice Channels that can be expanded as needed.

### Increasing the number of Voice Channels

On the BIC you can have a maximum 32 Voice Channels. If you want to add more than eight Voice Channels you must add a Media Services Processor Expansion Card (PEC) Type A to the BIC. The PEC allows the addition of more Voice Channels. For example, a BIC (without any PECs) can have a maximum of 8 Voice Channels, a BIC with one PEC can have a maximum of 16 Voice Channels, a BIC with two PECs can have a maximum of 24 Voice Channels and a BIC with 3 PECs can have a maximum of 32 Voice Channels.

**Table 2 Maximum Voice Channels**

BIC with no PECs	BIC with 1 PEC	BIC with 2 PECs	BIC with 3 PECs
8 Voice Channels maximum	16 Voice Channels maximum	24 Voice Channels maximum	32 Voice Channels maximum

This document does not provide instructions for enabling Voice Channels. Voice Channels are enabled by application-specific Security Key Codes. For more information about enabling Voice Channels, refer to the upgrade documentation that came with the application(s) installed on the NAM.

For information on adding a PEC card to the BIC, refer to "Installing a PEC in the NAM" on page 52.

## Installing a PEC in the NAM

1. Shutdown the NAM. For more information, refer to "Shutting down the NAM" on page 34.
2. Remove the NAM power cord from the AC outlet.
3. Ground yourself by attaching one end of the grounding strap to your wrist and the other end to a grounded metal surface.
4. Remove the NAM front cover. Refer to "Removing the front cover" on page 36.
5. Locate the appropriate PEC slot on the BIC. The first PEC is installed in PEC slot 1. The second PEC is installed in PEC slot 2. The third PEC is installed in PEC slot 3. For PEC slot locations on the BIC, refer to Figure 19 on page 52.

Figure 19 PEC slot assignment

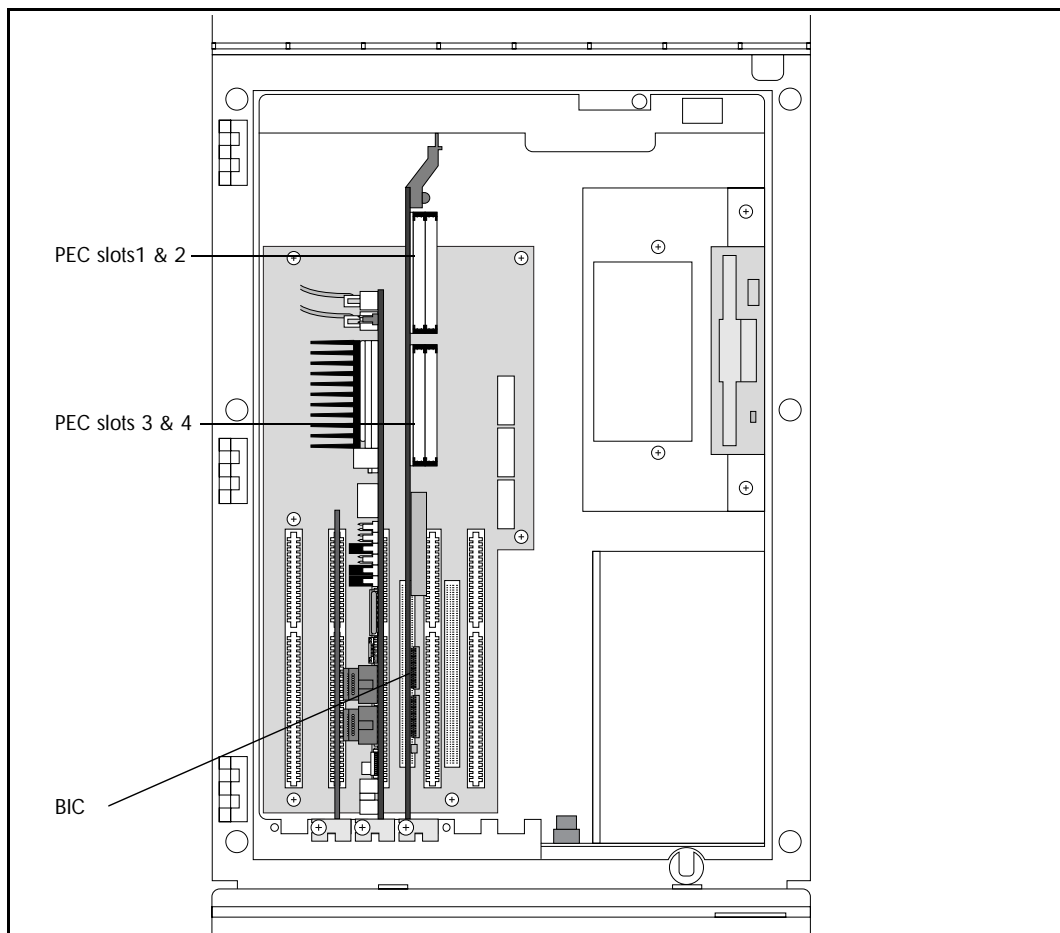

6. Gently slide the PEC into the PEC slot on the BIC. Ensure the PEC snaps into place. The PEC is keyed and cannot be installed incorrectly. Do not force the PEC into place.

Figure 20 Installing a PEC on the BIC

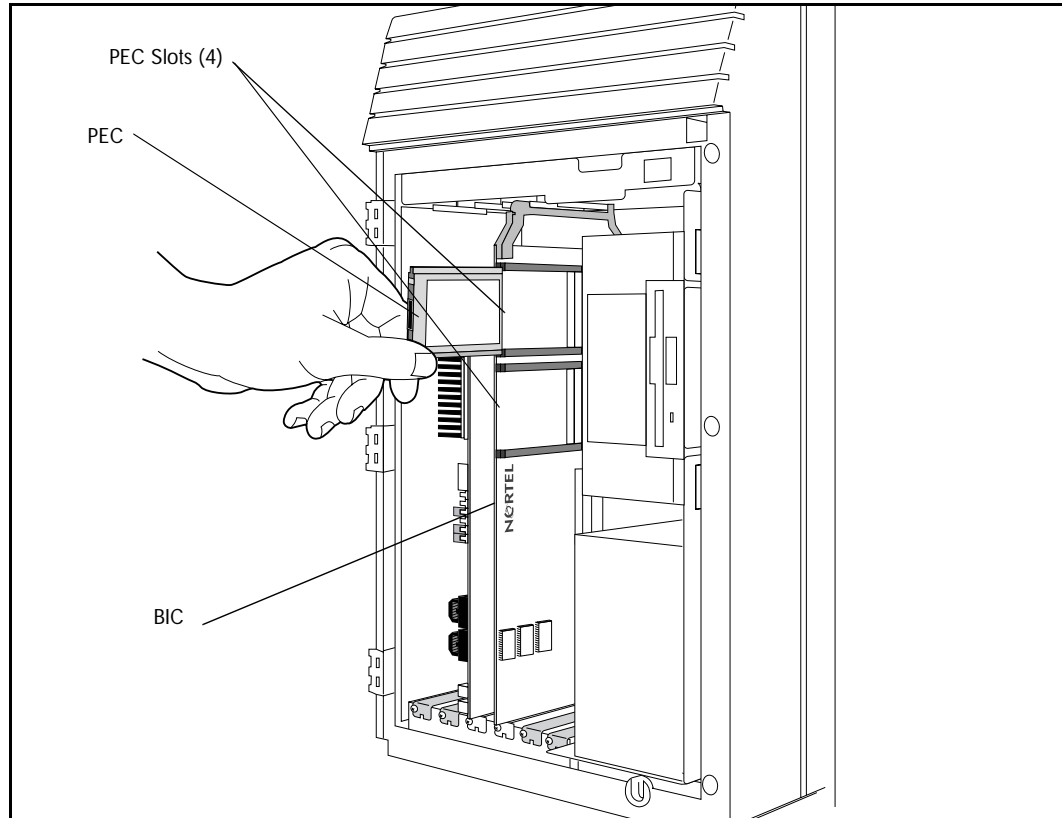

7. Close the module door. To lock the door, turn the lock 90° clockwise until the screwdriver slot is horizontal.
8. Plug the power cord into the AC outlet.

## Removing the BIC

The BIC is removed when a failure is suspected or when a Media Services Bus Expansion Card (BEC) is being added to the BIC. The BEC is installed along with a Digital Fax Card (DFC) to provide the NAM fax capability. For more information on the BEC, refer to "Installing the Media Services Bus Expansion Card (BEC) on the BIC" on page 44.

To remove the BIC:

1. Shutdown the NAM. For more information, refer to "Shutting down the NAM" on page 34.
2. Remove the NAM power cord from the AC outlet.
3. Ground yourself by attaching one end of the grounding strap to your wrist and the other end to a grounded metal surface.
4. Remove the front cover. Refer to "Removing the front cover" on page 36.
5. Locate the BIC in slot 4 and disconnect the fiber cable.
6. Remove the slot cover screw.
7. Use both hands to carefully hold the BIC along the top. Lift the BIC straight up and out from the module. Sometimes the BIC is tightly seated and difficult to remove. You may need to wiggle it out with a slight rocking motion.

## Re-installing the BIC

Before you begin to install the BIC, ensure you have an antistatic ground strap.

To re-install the BIC:

1. Ground yourself by attaching one end of the grounding strap to your wrist and the other end to a grounded metal surface.
2. Unpack the BIC from the shipping container and antistatic bag. Inspect for damage. Handle the board by its edges at all times. Do not touch any card components.

3. Locate expansion slot 4. For more information about the different card slots, refer to Figure 1 on page 13. Remove the slot cover screw and the metal slot cover.

**Note:** When replacing the BIC you must install any PECs or the BEC if it was installed on the original BIC. For instruction on installing a BEC, refer to "Installing the Media Services Bus Expansion Card (BEC) on the BIC" on page 44. For information on installing a PEC, refer to "Installing a PEC in the NAM" on page 52.

4. Carefully hold the BIC along the top. Insert the card by aligning it between the metal groove on one side and the slot opening on the other side.

Figure 21 Installing the BIC

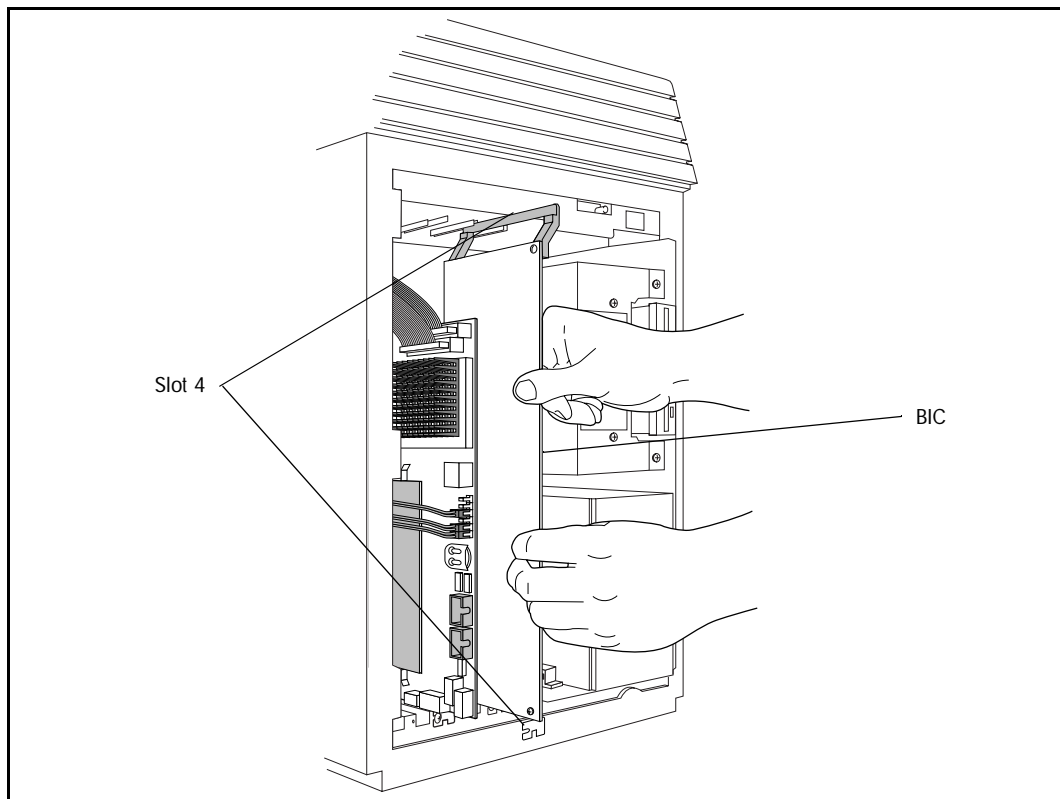

5. Push the BIC straight back until it fits snugly in place. Ensure the edge connector is firmly inserted into the socket.
6. Fasten the slot cover screw in the BIC slot cover.
7. Replace the front cover.
8. Plug the power cord into the AC outlet.

## Overview

When you are replacing the floppy disk drive, you must remove the front cover and the plastic case enclosing the Norstar Applications Module (NAM). The screws holding the floppy disk drive in place are only accessible from the outside edge of the module.

### Installing a new floppy disk drive

To remove the floppy disk drive:

1. Shutdown the module. For more information, refer to "Shutting down the NAM" on page 34.
2. Remove the NAM power cord from the AC outlet.
3. Remove the hard disk drive mounting bracket. For more information refer to "Removing the hard disk drive" on page 60.
4. Remove the front cover and plastic case. For more information about removing the front cover and plastic case, refer to "Accessing the inside of the NAM" on page 35.
5. Ground yourself by attaching one end of the grounding strap to your wrist and the other end to a grounded metal surface.
6. Loosen, but do not remove the two screws that fasten the floppy disk drive to the module wall. Slowly lift the floppy drive up and away from the module wall.
7. Disconnect the power supply wiring and ribbon cable from the floppy disk drive.

Figure 22 Removing the floppy disk drive

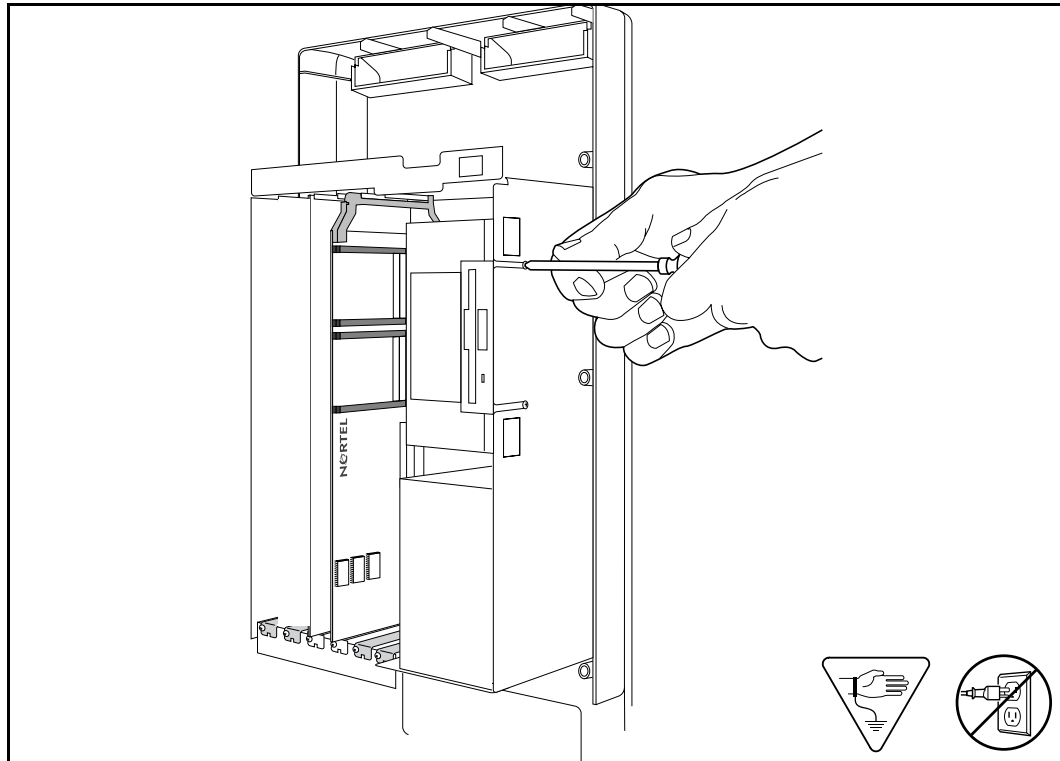

To install a new floppy disk drive:

1. Connect the power supply wiring and ribbon cable to the floppy disk drive.
2. Slide the floppy disk drive with its two screws still attached into the two mounting slots in the module wall.
3. Fasten the screws.
4. Replace the front cover and plastic case.
5. Plug the power cord into the AC outlet.

---

# Installing and upgrading the hard disk drive

## Overview

The Norstar Applications Module (NAM) includes one factory installed hard disk drive. This hard disk drive can be replaced if a problem exists.

When you replace a hard disk, you must backup and restore the NAM capabilities file.

**Table 3** Hard disk drive summary

Hard Disk Drive	Hours of message storage* (minimum)
Primary	100
Secondary	130

\*Approximate - the amount of message storage time depends on the applications installed on the NAM hard disk drive.

## Backing up the NAM capabilities file

You must back up the capabilities file SEKUR. The SEKUR file contains all upgrade and capability information about your system, including the number of voice channels and any upgrades to your system. The SEKUR file must be restored if a hard disk failure occurs.

If this file is lost and your hard disk drive fails, all upgrades made to your system will be lost.

**Note:** Before you begin, ensure you have a blank high density formatted 1.44 MB 3.5" floppy disk. Label the disk **SEKUR/Capabilities File**.

To back up the NAM capabilities file:

1. Press     .

Password:  
RETRY

2. Enter the ACCESS password.

**Note:** The default password is ACCESS2  
(2223772).

ACCESS Server  
BACK NEXT ADMIN

3. Press ADMIN .

A. Prt. queue mgr  
QUIT NEXT SHOW

4. Press NEXT until the display shows **E. Bckp/Rstr.**

E. Bckp/Rstr  
QUIT NEXT SHOW

5. Press SHOW .

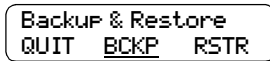

6. Press **BCKP**.

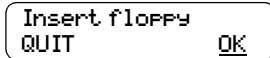

7. Insert a formatted floppy disk and press **OK**.

8. Wait until the backup is complete.

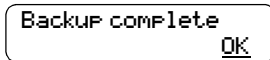

9. Press **OK**.  
Press **RLS** to end this session.

Once you have backed up the NAM capabilities file, make sure you store the floppy disk in a safe place.

### Removing the hard disk drive



**CAUTION**

Do not use an electric screwdriver near the hard disk drive. Information on the disk could be lost. Refer to **Special tools** earlier in this section for equipment recommendations.

1. Shutdown the NAM. For more information, refer to "Shutting down the NAM" on page 34.
2. Remove the NAM power cord from the AC outlet.
3. Ground yourself by attaching one end of the grounding strap to your wrist and the other end to a grounded metal surface.
4. Remove the front cover. Refer to "Accessing the inside of the NAM" on page 35.
5. The hard disk drive(s) are held by a bracket attached to the module wall. Remove the two screws located on the right hand side on the top and bottom of the bracket. Gently pull the bracket away the module wall.
6. Disconnect the power supply wiring and ribbon cable from the hard disk drive. If another hard disk drive is installed, its wiring and cabling must also be disconnected.



**CAUTION**

Ensure the hard disk drive bracket does not fall onto the NAM components.

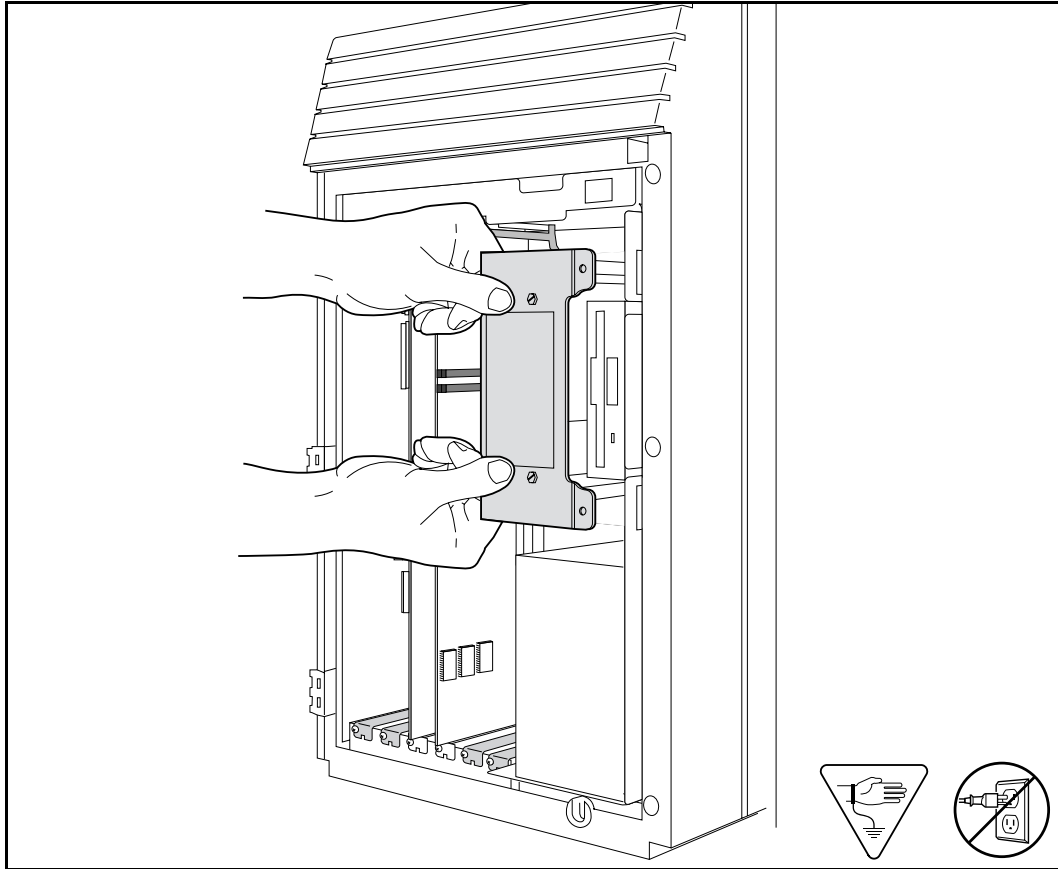
**Figure 23 Removing the hard disk drive mounting bracket**

7. Lift the bracket out of the module.
8. Remove the four screws that fasten the hard disk drive to the bracket. Two screws are located on each side of the hard disk drive.
9. Pull the hard disk drive out from the bracket.

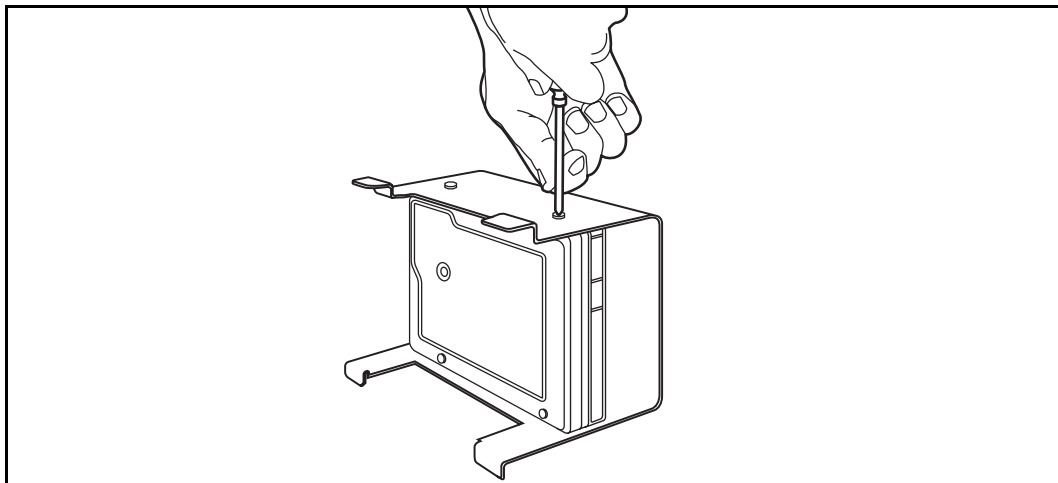
**Figure 24 Removing the hard disk drive from bracket**



**CAUTION**

Shock can damage the hard disk. Do not drop or bump the hard disk drive.

If you are returning the hard disk drive to a Nortel repair facility, package it carefully in the box that the replacement disk drive came in. If you do not have the original box, package the drive in another box with plenty of shock-absorbing material.

### Installing a new hard disk drive

Before you can install a new hard disk drive, you must remove the hard disk drive bracket from the NAM. When you are replacing the hard disk drive, you must also remove the existing hard disk from the disk drive bracket.

To install a new hard disk drive:

1. Fasten the hard disk drive to the bracket. The hard drive must be positioned with the bottom of the hard disk drive (the side with the exposed electronic connectors) facing into the module. Refer to Figure 1 on page 13 for the location of the hard disk drive.
2. Connect the hard disk drive power supply wiring and ribbon cable. The connector at the end of the ribbon cable is used for the primary hard disk drive.

**Note:** All connectors are keyed or shaped so they cannot be inserted backwards. If you cannot push a connector in easily, do not force it.

3. Insert the tongues on the bracket into the holes in the module wall.
4. Press the bracket firmly against the module wall so each of the two screw holes line up.
5. Fasten the bracket to the module.
6. Replace the front cover.
7. Plug the power cord into the AC outlet.

## Restoring the NAM capabilities file

If your system fails and a new hard disk drive is installed, the new drive is installed with all the necessary system software. The SEKUR file contains all upgrade and capability information about your system and must be restored if a hard disk failure occurs. If this file is lost and your hard disk drive fails, all upgrades made to your system will be lost.

When you restore the SEKUR file you must make sure you are restoring the most recent backup.

To restore the NAM capabilities file:

1. Press     .

```

Password:
                RETRY
  
```

2. Enter the ACCESS password.

**Note:** The default password is ACCESS2 (2223772).

```

ACCESS Server
BACK  NEXT  ADMIN
  
```

3. Press ADMIN .

```

A. Prt queue mgr
QUIT  NEXT  SHOW
  
```

4. Press NEXT until the display shows E. Bckp/Rstr .

```

E. Bckp/Rstr
QUIT  NEXT  SHOW
  
```

5. Press SHOW .

```

Backup & Restore
QUIT  BCKP  RSTR
  
```

6. Press RSTR .

```

Insert floppy
QUIT                OK
  
```

7. Insert the backup disk and press OK .

8. Wait until the restore completes.

```

Restore complete
                OK
  
```

9. Press OK .

10. Press to  end this ACCESS programming session.

## Adding a secondary hard disk drive

Before you can install a secondary hard disk drive, you must remove the hard disk drive bracket from the NAM. When you are adding a secondary hard disk drive, installation is easier if you first loosen two screws on the first drive. You must make sure you tighten all screws on the first disk drive when installation is complete.

You must back up the capabilities file SEKUR. The SEKUR file contains all upgrade and capability information about your system, including the number of voice channels and any upgrades to your system. The SEKUR file must be restored if a hard disk failure occurs.

If this file is lost and your hard disk drive fails, all upgrades made to your system will be lost. Refer to 'Backing up the NAM capabilities file' on page 59.

Adding a secondary hard disk drive:

1. Remove the hard disk drive and bracket from the NAM. Refer to the figure "Removing the hard disk drive" on page 60. Do not remove the primary hard disk drive from the bracket
2. Fasten the secondary hard disk drive to the bracket next to the primary hard disk drive. The secondary hard disk drive must be positioned with the bottom of the hard disk drive (the side with the exposed electronic connectors) facing into the module. Use the placement of the primary hard disk drive as an example.

**Note:** Refer to Figure 23 on page 61 for the location of the hard disk drives.

3. Set the jumper position for the secondary hard disk drive. Refer to the jumper position diagram located on the secondary hard disk drive.

**Note:** Master refers to the jumper settings for the primary hard disk drive and Slave refers to the jumper settings for the secondary hard disk drive.

4. Connect the hard disk drive power supply wiring and ribbon cable. The connector at the end of the ribbon cable is used for the primary hard disk drive.

**Note:** All connectors are keyed or shaped so they cannot be inserted backwards. If you cannot push a connector in easily, do not force it.

5. Insert the tongues on the bracket into the holes in the module wall.
6. Press the bracket firmly against the module wall so each of the two screw holes line up.
7. Fasten the bracket to the module.



**CAUTION**

All connectors are keyed or shaped so they cannot be inserted backwards. If you cannot push a connector in easily, do not force it.

8. Replace the front cover.
9. Plug in the module.
10. You must allocate hard disk drive space to the secondary hard disk drive. For more information on allocating disk space to the secondary hard disk drive, refer to 'Allocating and restricting hard disk drive space' on page 94.

## Overview

The Norstar Applications Module (NAM) is equipped with 32 MB of SDRAM. This memory is located in a Dual In-line Memory Module (DIMM) on the SBC. The DIMM is located in memory slot 1. For information about the location of the DIMM slots, refer to Figure 26 on page 69.

## Adding memory

You may want to increase the amount of SDRAM depending on the applications running on the NAM. You can expand the amount of SDRAM by adding one 32 MB DIMM to expand to 64 MB or one 64 MB DIMM to expand to 96 MB.

**Note:** Before you begin installing additional memory, make sure you [ground](#) yourself by attaching one end of the [grounding](#) strap to your wrist and the other end to a [grounded](#) metal surface.



### **CAUTION**

Do not use an electric screwdriver or any other magnetized tools near the DIMMs or the hard drive. The DIMMs may be disrupted. Refer to "Special parts and equipment" on page 22 for equipment recommendations.

To add memory:

1. Shutdown the NAM. For more information, refer to "Shutting down the NAM" on page 34.
2. Remove the NAM [power cord](#) from the AC [outlet](#).
3. [Ground](#) yourself by attaching one end of the [grounding](#) strap to your wrist and the other end to a [grounded](#) metal surface.
4. Remove the front cover. Refer to "Removing the front cover" on page 36.
5. Disconnect the Serial Port A and Serial Port B connectors from the SBC. Refer to Figure 25 on page 68.
6. Disconnect the three connectors from the side of the SBC. Disconnect the three ribbon cable connectors on the top of the SBC. Refer to Figure 25.
7. Remove the SBC slot cover screw.

Figure 25 Disconnecting connectors and ribbon cables from the top of the SBC

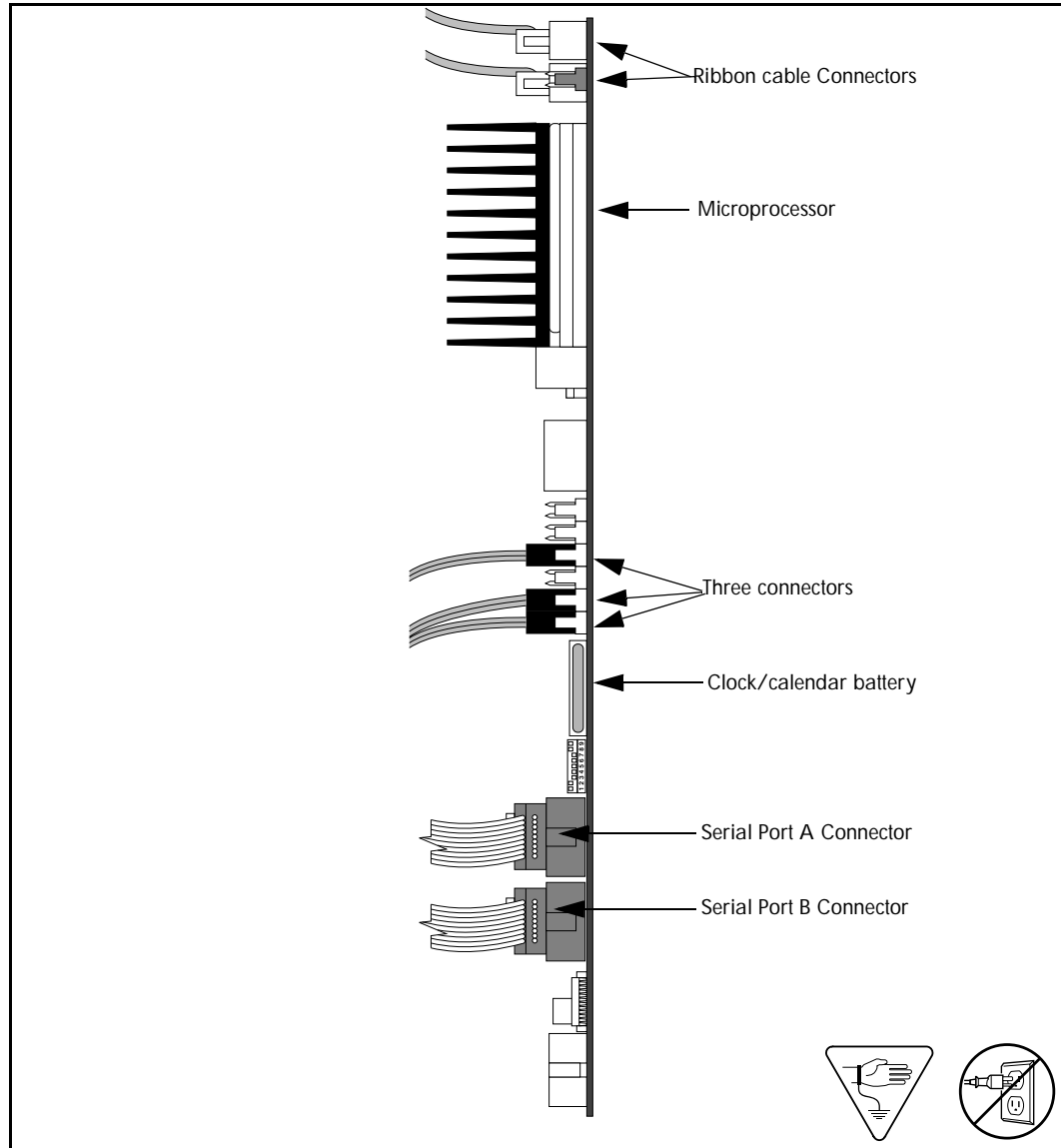
**WARNING**

The microprocessor heat sink may be hot. Pay careful attention not to touch the heat sink while removing or installing the SBC.

8. Use both hands to carefully hold the SBC along the top. Lift the SBC straight up and out from the NAM. Sometimes the SBC is tightly seated and hard to remove. You may need to wiggle it out with a slight rocking motion.
9. Place the SBC on a flat surface, with the heat sink facing up. Refer to Figure 26.

**Caution**

Failure to place the SBC on a flat surface may result in serious damage to the SBC. While the SBC is out of the NAM, be careful not to slide or catch the back of the SBC, this may cause the modules to become damaged.

10. Push the DIMM straight, edge connectors first, into the slot. Refer to Figure 26.

**Note:** The DIMM cannot be inserted upside-down. The DIMM has a notch which lines up with a post on the SBC DIMM slot. Do not force the DIMM into its slot.

Figure 26 Installing a DIMM on the SBC.

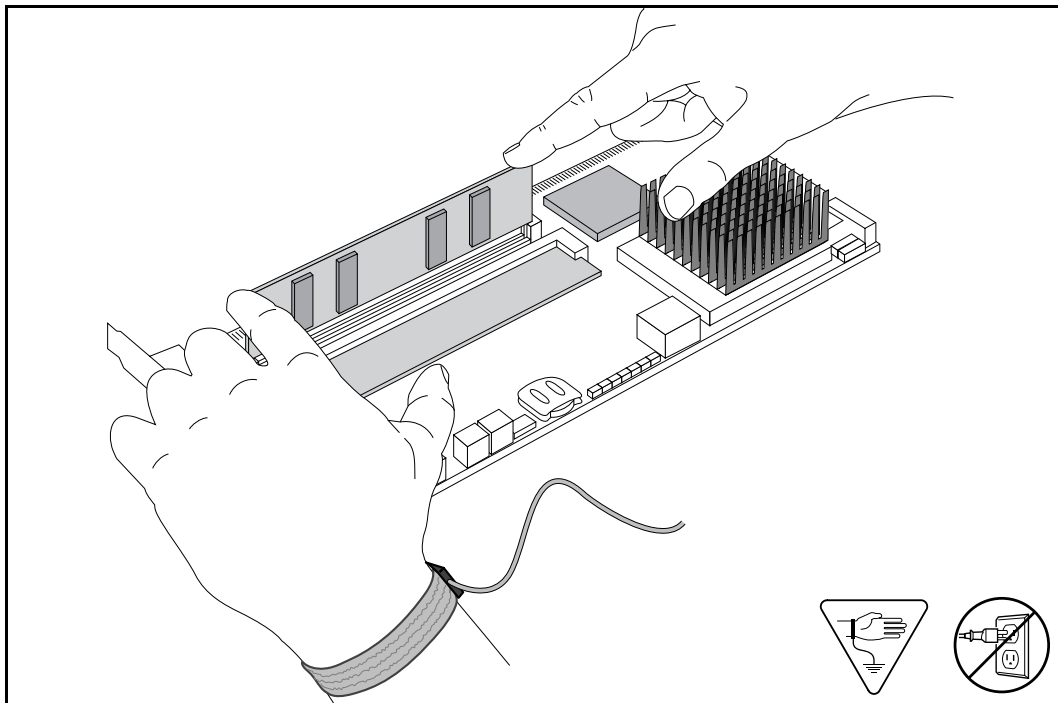

11. Gently push the DIMM into the clips. The clips should snap onto the sides of the DIMM.
12. Carefully hold the SBC along the top. Insert the card by aligning it between the metal groove on one side and the slot opening on the other side.
13. Push the SBC straight back until it fits snugly in place. Ensure the edge connector is firmly inserted into the backplane socket.
14. Reconnect the Serial Port A and Serial Port B connectors to the SBC. Refer to Figure 25 on page 68 for the location of the connectors.

15. Reconnect the three connectors from the side of the SBC. Reconnect the three ribbon cable connectors near the top of the SBC. Refer to Figure 25 on page 68 for the proper alignment of the connectors.
16. Fasten the slot cover screw.
17. Replace the front cover.
18. Plug the [power cord](#) into the AC [outlet](#).

The NAM will reboot and then automatically reboot a second time. The second reboot is necessary for the NAM to recognize the addition of memory.

## Removing memory

A DIMM is usually only removed when a failure is suspected.

**Note:** There must be at least one DIMM installed in the NAM in order for the NAM to be functional.

To remove a DIMM:

1. Shutdown the NAM. For more information, refer to "Shutting down the NAM" on page 34.
2. Remove the NAM [power cord](#) from the AC [outlet](#).
3. [Ground](#) yourself by attaching one end of the [grounding](#) strap to your wrist and the other end to a [grounded](#) metal surface.
4. Remove module front cover. Refer to "Accessing the inside of the NAM" on page 35.
5. Disconnect the Serial Port A and Serial Port B connectors from the SBC. Refer to Figure 25 on page 68.
6. Disconnect the three connectors from the side of the SBC. Disconnect the three ribbon cable connectors on the top of the SBC. Refer to Figure 25 on page 68.



**WARNING**

The microprocessor heat sink may be hot. Pay careful attention not to touch the heat sink while removing or installing the SBC.

7. Remove the SBC slot cover screw.

8. Use both hands to carefully hold the SBC along the top. Lift the SBC straight up and out from the module. Sometimes the SBC is tightly seated and hard to remove. You may need to wiggle it out with a slight rocking motion.
9. Place the SBC on a flat surface, with the DIMM slot facing up. Refer to the figure "Location of the DIMM" on page 71.



**Caution**

Failure to place the SBC on a flat surface may result in serious damage to the SBC. While the SBC is out of the NAM, be careful not to slide or catch the back of the SBC, this may cause the modules on the back of the SBC to become damaged.

10. Each DIMM is connected to the SBC by two clips on each side of the DIMM's edge connector. Gently push each clip away from the DIMM until it unlatches from the DIMM.
11. Remove the DIMM from the slot.

**Figure 27** Location of the DIMM

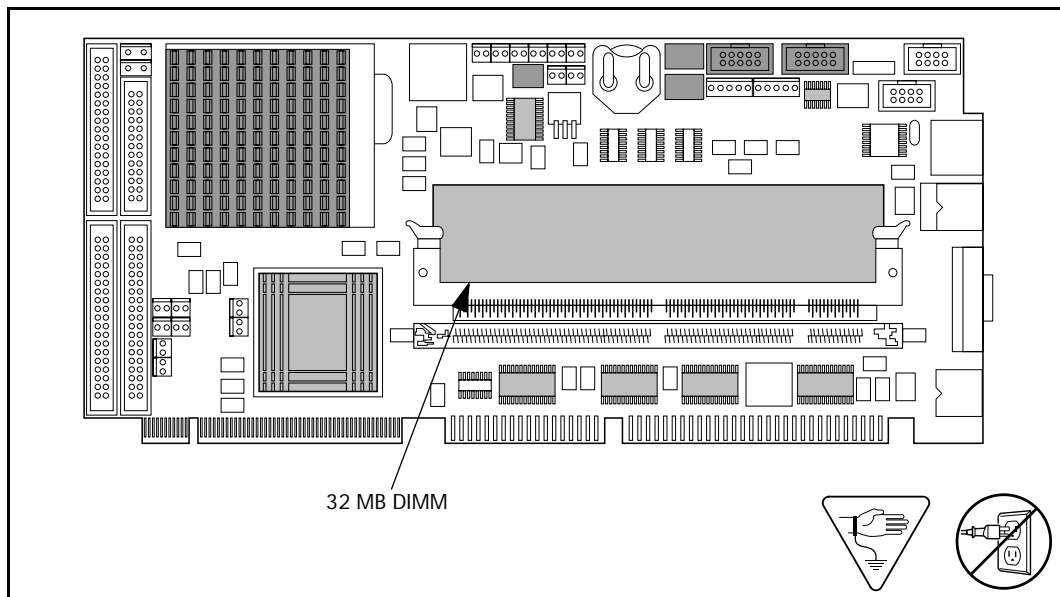

12. Push the replacement DIMM straight, edge connectors first, into the slot.

**Note:** The DIMM cannot be inserted upside-down. The DIMM has a notch which lines up with a post on the SBC DIMM slot. Do not force the DIMM into its slot.

13. Carefully hold the SBC along the top. Insert the card by aligning it between the metal groove on one side and the slot opening on the other side.

14. Gently push the DIMM into the clips. The clips should snap onto the sides of the DIMM.
15. Push the SBC straight down until it fits snugly in place. Ensure the edge connector is firmly inserted into the backplane socket.
16. Reconnect the Serial Port A and Serial Port B connectors to the SBC. Refer to Figure 25 on page 68 for the location of the connectors.
17. Reconnect the three connectors to the side of the SBC. Reconnect the three ribbon cable connectors to the top of the SBC. Refer to Figure 25 on page 68 for the proper alignment of the connectors.
18. Fasten the slot cover screw.
19. Replace the front cover.
20. Plug the [power cord](#) into the AC [outlet](#).

---

# Adding and removing a monitor, keyboard and mouse

11

## Overview

A 14 inch color monitor, a keyboard and a mouse can be added to the Norstar Applications Module (NAM) to allow the use of other Nortel approved software applications on the NAM. The monitor comes with a Super Video Graphic Array (SVGA) card.

## Connecting the montior, keyboard and mouse

1. Shutdown the NAM. For more information, refer to "Shutting down the NAM" on page 34.
2. Remove the NAM power cord from the AC outlet.
3. Plug the monitor, keyboard and mouse cables into the appropriate ports located on the bottom of the SBC. Refer to Figure 28 for the location of each port.

Figure 28 Bottom view - external points of connection for SBC mounted video card

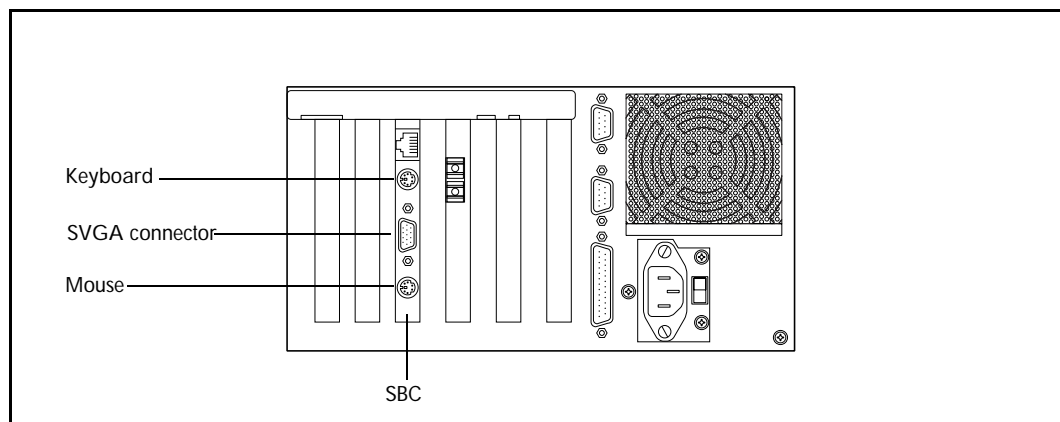

4. Plug the power cord into the AC outlet.

## Enabling the monitor, keyboard and mouse

After you have added the monitor, keyboard and mouse, you must enable them. This is necessary for the NAM software to recognize the addition of the components.

To enable the monitor, keyboard and mouse:

1. Press     .

2. Enter the ACCESS password.

**Note:** The default password is ACCESS2 (2223772).

3. Press ADMIN .

4. Press NEXT until the display shows G. Monitor Pkg.

5. Press SHOW .

6. Enter the default password           (SVGANEDED).

7. Press ADD .

8. Reboot the system from a Norstar telephone. For more information, refer to "Rebooting the NAM" on page 92.

9. While the system is rebooting the monitor will go blank. Watch the screen during the reboot. When a small white OS/2 box appears in the top left corner, you must immediately press  and  at the same time. The flashing white box only appears on the screen for 2 seconds.

**Note:** If you were unable to press  and  while the white OS/2 box appeared, cycle the power to the NAM and repeat step 9.

10. When the **Recovery Choices** screen appears on the monitor, press  on the keyboard.

- The monitor, keyboard and mouse have now been initialized and enabled.

**Note:** Steps 9 and 10 are part of a first time monitor initialization process. If the monitor, keyboard and mouse are removed from the NAM, only steps 1 through 8 need to be performed to re-enable the monitor package.

## Removing the monitor, keyboard and mouse

If you remove the monitor, keyboard, mouse and SVGA card you must first disable the monitor package. This is necessary for the NAM software to recognize the removal of the components.

To remove the monitor, keyboard and mouse:

- Press     .

Password:  
RETRY

- Enter the ACCESS password.

**Note:** The default password is ACCESS2 (2223772).

ACCESS Server  
BACK NEXT ADMIN

- Press ADMIN .

A. Prt queue mgr  
QUIT NEXT SHOW

- Press NEXT until the display shows G. Monitor Pkg .

G. Monitor Pkg  
QUIT NEXT SHOW

- Press SHOW .

Password:  
QUIT RETRY

- Enter the default password           (SVGANEDED).

Monitor?  
QUIT ADD REM

- Press REM .

Reboot needed

- Shut down the NAM. For more information, refer to "Shutting down the NAM" on page 34.

- Remove the NAM power cord from the AC outlet.

- Disconnect the monitor, keyboard and mouse from the SBC.

11. Plug the power cord into the AC outlet.

The power supply is set at the factory to operate at 115 volts, but the power supply can be changed to operate at 230 volts for countries where this is the standard. If you are changing the power supply voltage setting to 230 volts, the Norstar Applications Module (NAM) must be unplugged.

To change the power supply setting:

1. Shutdown the NAM. For more information, refer to "Shutting down the NAM" on page 34.
2. Remove the NAM power cord from the AC outlet.
3. Slide the slider switch, mounted on the bottom of the power supply, so that the desired voltage label is shown (115 or 230).
4. Replace the module on its wall mount.
5. Plug the power cord into the AC outlet.

Figure 29 Changing the power supply voltage

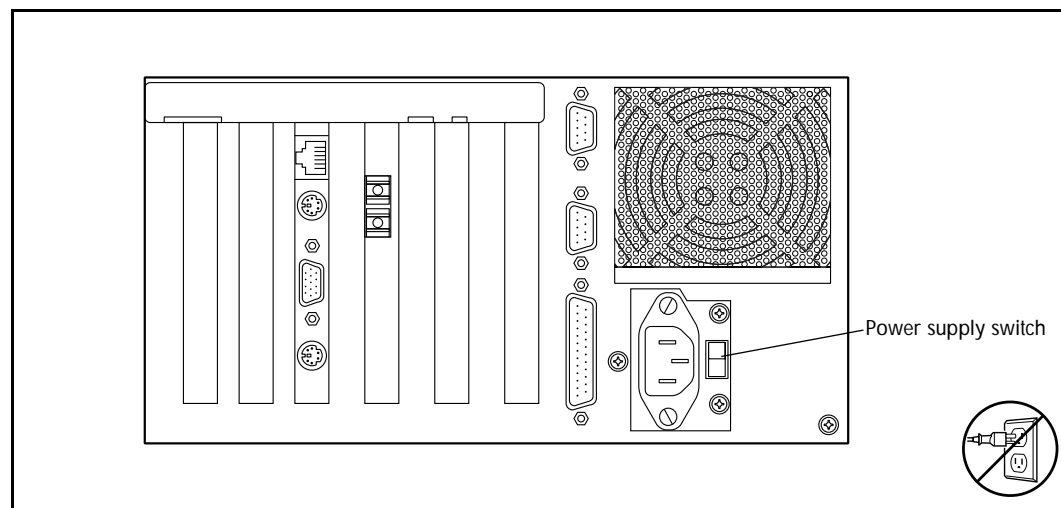

**CAUTION**

This unit is set at the factory to use 115 volts AC. Failure to change the power supply voltage setting when using 230 volts AC will damage the unit beyond repair.

# Installing and replacing the Single Board Computer (SBC)

## Overview

The Single Board Computer (SBC) is the main computing device of the Norstar Applications Module (NAM). It runs the operating system and all applications installed on the NAM. The microprocessor, clock/calendar battery and two Dual In-Line Memory Modules (DIMM) slots are located on the SBC.

The SBC is removed when a failure is suspected or confirmed.

Figure 30 Components of the SBC

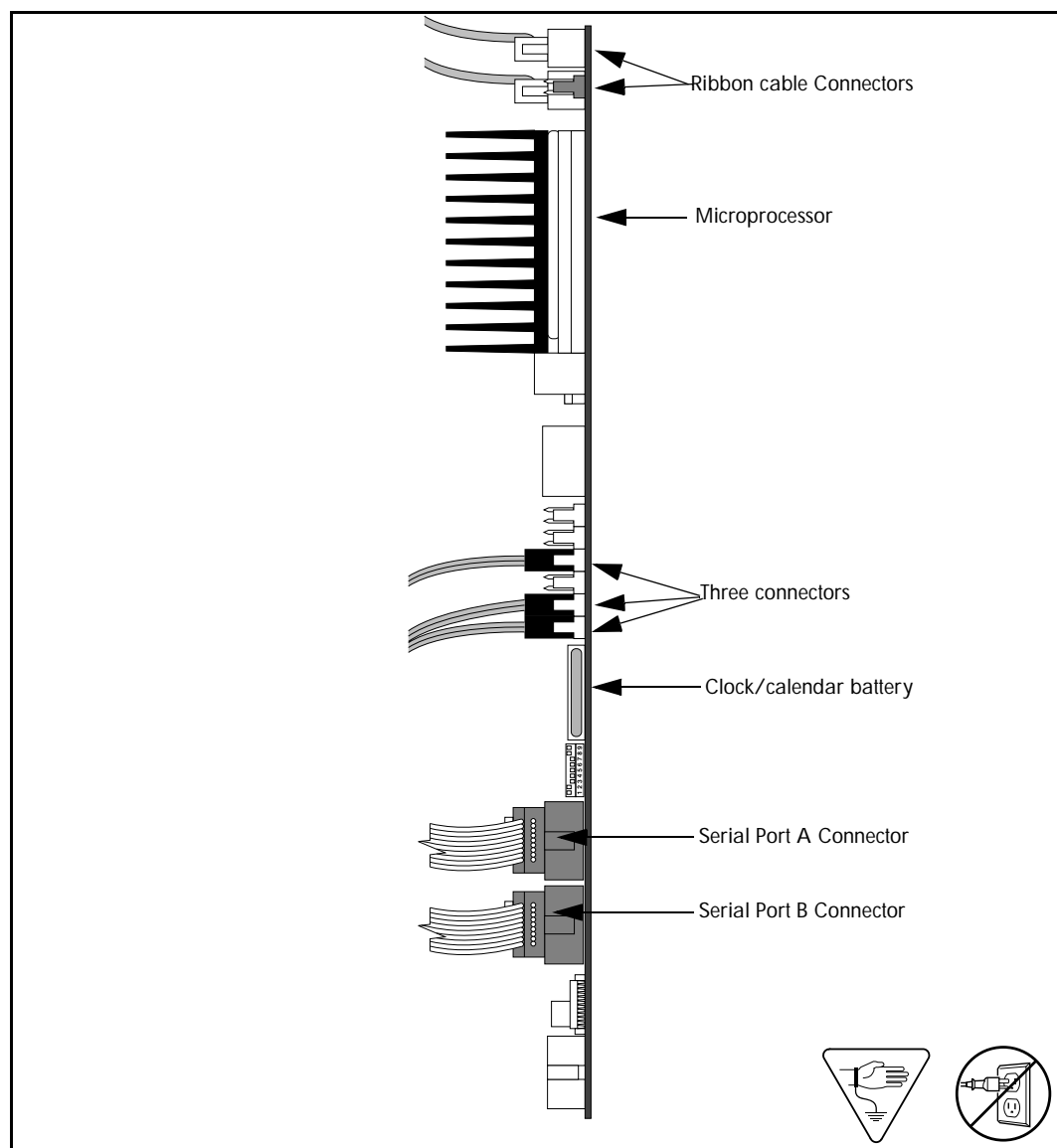

## Removing and replacing the SBC

To remove and replace the SBC:

1. Shutdown the NAM. For more information, refer to "Shutting down the NAM" on page 34.
2. Remove the NAM power cord from the AC outlet.
3. Ground yourself by attaching one end of the grounding strap to your wrist and the other end to a grounded metal surface.
4. Remove the NAM front cover. Refer to "Accessing the inside of the NAM" on page 35.
5. Locate slot 3 and remove its slot cover screw and metal slot cover.
6. Disconnect the Serial Port A and Serial Port B connectors from the SBC. Refer to Figure 30 on page 79.
7. Disconnect the three connectors from the side of the SBC. Disconnect the three ribbon cable connectors from the top of the SBC. Refer to Refer to Figure 30 on page 79.
8. Use both hands to carefully hold the SBC along the top. Lift the SBC straight up and out from the module. Sometimes the SBC is tightly seated and hard to remove. You may need to wiggle it out with a slight rocking motion.
9. If you are returning the NAM for service, place the SBC in an antistatic bag. Package the SBC with plenty of shock-absorbing, insulating material.
10. Unpack the replacement SBC from the shipping container and antistatic bag. Inspect for damage. Handle the board by its edges at all times. Do not touch any card components.
11. Carefully hold the card along the top only and insert the card into the module by aligning it over the backplane connector.

Figure 31 Installing the SBC

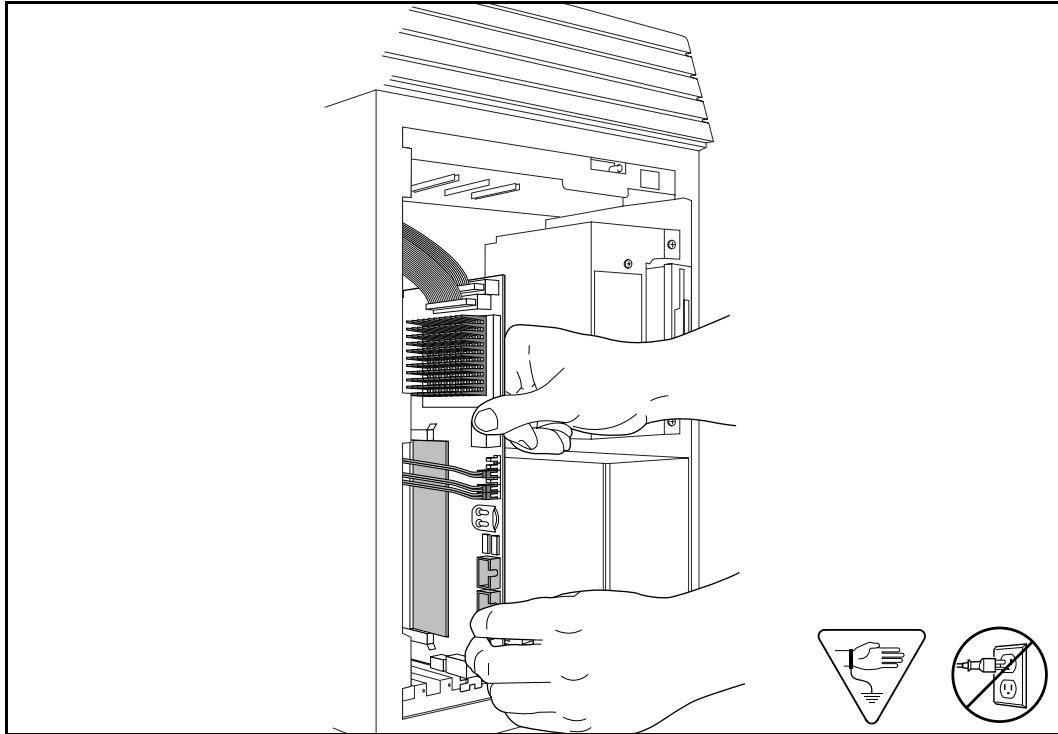

12. Push the card straight down until it fits snugly in place. Ensure the edge connector is firmly inserted into the backplane connector. Refer to Figure 31.
13. Fasten the slot cover screw.
14. Reconnect the Serial Port A and Serial Port B connectors to the SBC. Refer to Figure 30 on page 79 for the location of the connectors.
15. Reconnect the three connectors to the side of the SBC. Reconnect the three ribbon cable connectors to the top of the SBC. Refer to Figure 30 on page 79 for the proper alignment of the connectors.
16. Replace the front cover.
17. Plug the power cord into the AC outlet.

---

## **Section IV - ACCESS Server Administration**

- Using the ACCESS Server Administration software

## Overview

The ACCESS Server software resides on the Norstar Applications Module (NAM). The ACCESS Server Administration software is designed to communicate with the Norstar system and provide support for applications running on the NAM. The ACCESS Server provides services to a group of devices including:

- routing of all voice commands between applications and the Media Service Base Interface Card (BIC)
- provision of special features, such as supporting application installation and shutting down the system
- management of all shared resources of the platform, such as Voice and Fax Channels, that are not managed directly by the operating system

You can use access the ACCESS Server Administration software from any two-line display Norstar telephone connected to your NAM.

The Server Administration software allows you to:

- administer the printer queue
- set the DTMF digit duration length
- view the Alarm and Message log
- share Voice and Fax Channels between applications
- install applications
- view the NAM serial number
- shutdown or reboot the system
- schedule a reboot of the system
- set up hard disk drive restrictions
- renumber Norstar Voice Mail Lines (requires a diskette)
- view the Channel Status, refer to "Checking the Channel Status" on page 103.

## Using the ACCESS Server Administration software

### Changing the printer options

The Print Queue Manager allows you to hold, cancel, or resume all print jobs in the queue.

To change the printer options:

1. Press    .

2. Enter the default password ACCESS2 (      .

3. Press ADMIN.

4. Press SHOW.

The display shows the Printer Option Menu.

5. Press NEXT until you reach the printer option you want.

6. Follow the instructions on the display.

### Setting the DTMF digit duration length

Talk Off occurs when an application interprets certain voice patterns as tone dialing signals. Tone dialing signals are produced when keys are pressed on a touch tone telephone. When you press a key on the dialpad, the application receives a touch tone signal and performs the correct operation associated with that key.

For example, after you enter a password, you can press the  key. The touch tone signal sent indicates you are finished entering your password.

Some voice patterns are the same as the touch tone signal and this may cause an application to function incorrectly. For example, if in the middle of a message you said something that sounded the same as the touch tone signal created by pressing the  key, the recording session would end. Correcting Talk Off requires adjustments to the DTMF digit duration length.

The DTMF digit duration length can be 30, 40, 50 or 60 milliseconds (ms). The default is 40 ms. If the DTMF digit duration length is too low, the application may mistake speech for DTMF tones. If the DTMF digit duration length is too high, the application may fail to recognize the touch tone signals.

To change the DTMF digit duration length:

1. Press     .
2. Enter the default password ACCESS2 (       ).
3. Press NEXT until the display shows:
 

Password:  
RETRY
4. Press SHOW .
5. Press CHG to change the DTMF digit duration length. xx will be the DTMF digit duration length
6. Enter the new DTMF digit duration length and press OK. 30, 40, 50 or 60 ms are the only acceptable DTMF digit duration length values.
7. Press OK to accept the DTMF digit duration length.
8. Press  to end this session.

ACCESS Server  
 BACK NEXT ADMIN

DTMF Delay  
 BACK NEXT SHOW

DTMF delay: xx  
 QUIT CHG OK

DTMF delay: xx  
 QUIT RETRY OK

DTMF delay: XXms  
 QUIT CHG OK

## Viewing the Alarm and Message Log

The Alarm and Message Log keeps a record of system alarms and messages. Alarms and messages that repeat within five minutes will not be recorded unless other alarms or messages occur in the intervening time. This option allows you to view the alarms or clear the entire log file.

To view the Alarm and Message Log:

1. Press     .
2. Enter the default password ACCESS2 (       ).
3. Press ADMIN .
4. Press NEXT .
5. Press SHOW .

Password:  
RETRY

ACCESS Server  
 BACK NEXT ADMIN

A. Prt queue mgr  
 QUIT NEXT SHOW

B. Alarms & Msgs  
 QUIT NEXT SHOW

```
1. View Log
QUIT NEXT SHOW
```

6. Press **SHOW** to view the log.

**Note:** Press **NEXT** then **OK** to clear the log.

```
Start of Log
BACK NEXT QUIT
```

7. Press **NEXT** to scroll through the Alarms.

```
ALM:<Chan #3 59>
BACK NEXT TIME
```

8. Press **NEXT** to continue viewing the Alarms.

## Sharing Voice and Fax Channels between applications

If you are running multiple applications on the NAM, such as Norstar Voice Mail, MINUET or Norstar IVR applications, you can share Voice or Fax Channels between the applications. The ACCESS Server allows you to allocate Voice Channels by giving an application sole ownership of a Voice Channel or by assigning the Channel to a Channel Pool where it is shared by all applications.

You must assign a minimum and maximum number of Channels to be used by each application running on the NAM. Setting the minimum number of Channels dedicates a specific number of Channels to that application. Setting the maximum number of Channels allows you to choose the maximum number of Channels an application can use. The maximum Channel setting is a combination of the dedicated and shared Channels. For example, if you want an application to have 4 dedicated Channels and 2 shared Channels, the minimum setting would be 4 and the maximum setting would be 6.

The minimum number of Channels must not be greater than the number of Channels that are enabled for the application. For example, if an application has 6 Channels enabled and the minimum value is set to 8, 2 Channels are being dedicated to an application that cannot use them.

The maximum number of Channels cannot be greater than the maximum number of Channels allowed for an application. For example, Norstar Voice Mail can have a maximum value of 16 Channels, MINUET can have a maximum value of 4 Channels and Norstar IVR applications can have a maximum of 16 Channels.

After you have changed the minimum or maximum number of Channels for an application, you must reboot the NAM in order for the changes to take effect.

To set the minimum and maximum number of Channels for an application:

1. Press **Feature** **9** **1** **5** .

```
Password:
RETRY
```

2. Enter the default password ACCESS2 (**2** **2** **2** **3** **7** **7** **2**).

```
ACCESS Server
BACK NEXT ADMIN
```

3. Press **ADMIN** .

```
A. Prt queue mgr
QUIT  NEXT  SHOW
```

4. Press NEXT until the display shows the Voice and Fax heading.

```
C. Voice & Fax
QUIT  NEXT  SHOW
```

5. Press SHOW .

```
Choice of appl
QUIT          SHOW
```

6. Press SHOW until the display shows:

```
ACCESS Server
QUIT  NEXT  SHOW
```

7. Press NEXT until the application you want appears.

```
<Application>
QUIT  NEXT  SHOW
```

8. Press SHOW when the application you want appears on the screen.

```
a. Voice channel
QUIT  NEXT  SHOW
```

9. Press SHOW to change the minimum and maximum number of Voice Channels.

**Note:** Press NEXT and SHOW to change the minimum and maximum number of Fax Channels and follow steps 10 to 18.

```
Voice channels
QUIT  MIN  MAX
```

10. Press MIN to change the minimum number of Voice Channels dedicated to the application.

**Note:** To change the maximum number of Voice Channels dedicated to the application, proceed to step 13.

```
Min chans:X
DEC  INC  OK
```

11. Press INC to increase the minimum number of Voice Channels dedicated to the application. Continue pressing INC until you reach the desired number of Voice Channels.

Press DEC to decrease the minimum number of Voice Channels dedicated to the application. Continue pressing DEC until you reach the desired number of Voice Channels

```
Min chans:X
DEC  INC  OK
```

12. Press OK when you have reached the desired number of Voice Channels.

```
<Application>
QUIT  NEXT  SHOW
```

13. To change the maximum number of Voice Channels used by the application, press SHOW .

```
a. Voice channel
QUIT  NEXT  SHOW
```

14. Press SHOW .

```
Voice channels
QUIT  MIN  MAX
```

15. Press MAX to change the maximum number of Voice Channels (dedicated and shared) allocated to the application.

```
Max chans: X
DEC  INC  OK
```

16. Press INC to increase the maximum number of Voice Channels allocated to the application. Continue pressing INC until you reach the desired number of Voice Channels.

Press DEC to decrease the maximum number of Voice Channels allocated to the application. Continue pressing DEC until you reach the desired number of Voice Channels

```
Max chans: X
DEC  INC  OK
```

17. Press OK when you have reached the desired number of Voice Channels.

## Installing applications

The Install applications option allows you to install other software packages that work in conjunction with the applications already running on the NAM.

To install an application:

1. Press  9 1 5 .
2. Enter the default password ACCESS2  
(      ).
3. Press ADMIN .
4. Press NEXT until the display shows:
5. Press SHOW .
6. Press INSTL .

```

Password:
          RETRY
  
```

```

ACCESS Server
BACK  NEXT  ADMIN
  
```

```

A. Prt queue mgr
QUIT  NEXT  SHOW
  
```

```

H. Appl Install
QUIT  NEXT  SHOW
  
```

```

Insert floppy
QUIT      INSTL
  
```

## Viewing the NAM serial number

The serial number option allows you to view the serial number of the unit. This number is useful for verification and purchasing software options.

To view the serial number:

1. Press  9 1 5 .
2. Enter the default password ACCESS2  
(      ).
3. Press ADMIN .
4. Press NEXT until the display shows:
5. Press SHOW .
6. Press OK .

```

Password:
          RETRY
  
```

```

ACCESS Server
BACK  NEXT  ADMIN
  
```

```

A. Prt queue mgr
QUIT  NEXT  SHOW
  
```

```

I. Serial Number
QUIT  NEXT  SHOW
  
```

```

S#:XXXXXXXXXX
          OK
  
```

## Shutting down the NAM

This option allows you to “gently” shutdown the NAM. OS/2 Warp™ requires a controlled shutdown to guarantee the integrity of the file system.

Three shutdown options are available: Graceful, Quick and Immediate. The Graceful option allows an application to terminate all existing calls before shutting down. The Quick option only allows 45 seconds for an application to terminate before shutdown, and the Immediate option only allows 15 seconds.

When you are shutting down the NAM you will usually use the Graceful option. However, if the system is not responding to the command, you can speed up the process by changing the option to a Quick shutdown. After 45 seconds a Quick shutdown is performed.

To shutdown the NAM:

1. Press    .

Password:

2. Enter the default password ACCESS2 (      .

ACCESS Server  
BACK NEXT ADMIN

3. Press NEXT.

System shutdown  
BACK NEXT SHOW

4. Press SHOW.

Shutdown type  
QUIT NEXT GRACE

5. Press GRACE.

**Note:** Press NEXT to change the shutdown option to QUICK (Quick) or IMMD (Immediate).

Shutdwn Graceful  
YES NO

6. Press YES.

**Note:** Press NO if you want to stop the shutdown.

The NAM issues a series of tones descending in pitch when the shutdown is complete. Wait for the tones before you unplug the NAM.

## Rebooting the NAM

This option allows the installer to reboot the system. The Reboot option ensures all applications are terminated before a reboot is performed.

Four reboot options are available: Graceful, Quick, Immediate and Scheduled. The Graceful option allows an application to terminate all existing calls before shutting down and restarting. The Quick option only allows 45 seconds for an application to terminate before the reboot, and the Immediate option allows 15 seconds. For information on setting up a scheduled reboot, refer to 'Scheduling a reboot of the NAM' on page 93.

When you are rebooting NAM you will usually use the Graceful option. However, if the system is not responding to the command, you can speed up the process by changing the option to a Quick Reboot. After 45 seconds a Quick Reboot is performed.

To reboot the NAM:

1. Press  9 1 5 .

```

Password:
          RETRY
  
```

2. Enter the default password ACCESS2 (2 2 2 3 7 7 2).

```

ACCESS Server
BACK  NEXT  ADMIN
  
```

3. Press NEXT until the display shows:

```

System reboot
BACK  NEXT  SHOW
  
```

4. Press SHOW .

```

Reboot type
QUIT  NEXT  GRACE
  
```

5. Press GRACE .

**Note:** Press NEXT to change the shutdown option to QUICK (Quick), IMMED (Immediate) or SCHDL (Scheduled).

```

Reboot Graceful
YES          NO
  
```

6. Press YES .

**Note:** Press NO if you want to stop the reboot.

#### Scheduling a reboot of the NAM

This option allows you to schedule a time to reboot the system. This makes it possible to schedule a reboot of the system when it is not busy. The reboot option ensures all applications are terminated before a reboot is performed.

You must enter the time of the day, the day, month and year of when you want the reboot to take place. When the entered time is reached, the system will automatically reboot itself.

To schedule a reboot of the NAM:

1. Press  9 1 5 .

```

Password:
          RETRY
  
```

2. Enter the default password ACCESS2 (2 2 2 3 7 7 2).

```

ACCESS Server
BACK  NEXT  ADMIN
  
```

3. Press NEXT until the display shows:

```

System reboot
BACK  NEXT  SHOW
  
```

4. Press SHOW .

```
Reboot type
QUIT  NEXT  GRACE
```

5. Press NEXT until the display shows:

```
Reboot type
QUIT  NEXT  SCHDL
```

6. Press SCHDL .

```
yyyyymmdd#####
QUIT  RETRY  TIME
```

7. Press TIME .

### Allocating and restricting hard disk drive space

This option allows you to change the amount of disk space that is used by the applications on the NAM. This option is also used for allocating disk space to the secondary hard disk drive after it has been installed in the NAM.

To change the amount of disk space:

1. Press Feature 9 1 5 .

```
Password:
RETRY
```

2. Enter the default password ACCESS2  
( 2 2 2 3 7 7 2 ).

```
ACCESS Server
BACK  NEXT  ADMIN
```

3. Press ADMIN .

```
A. Prt queue mgr
QUIT  NEXT  SHOW
```

4. Press NEXT until the display shows:

```
F. Disk Restrict
QUIT  NEXT  SHOW
```

5. Press SHOW .

```
C: Rest:xxxxxxkb
NEXT  SIZE  CHG
```

6. Press CHG .

```
C: Rest:
QUIT  RETRY  OK
```

7. Enter the new restriction size of the hard disk drive and press OK .

```
C: Rest:xxxxxxkb
NEXT  SIZE  CHG
```

8. Press Rls to end this programming session

To allocate disk space to the secondary hard disk drive:

1. Press     .
2. Enter the default password ACCESS2  
(        ).
3. Press ADMIN .
4. Press NEXT until the display shows:
5. Press SHOW .
6. Press NEXT .
7. Enter the new restriction size of 999999 and press OK.
8. Press  to end this programming session

```

Password:
          RETRY
  
```

```

ACCESS Server
BACK  NEXT  ADMIN
  
```

```

A. Prt queue mgr
QUIT  NEXT  SHOW
  
```

```

F. Disk Restrict
QUIT  NEXT  SHOW
  
```

```

C: Rest:xxxxxxkb
NEXT  SIZE  CHG
  
```

```

D: Rest:
QUIT  RETRY  OK
  
```

```

D: Rest:xxxxxxkb
NEXT  SIZE  CHG
  
```

## Line renumbering

If your Norstar Voice Mail system is connected to a Modular ICS or Compact ICS, and you upgrade the ICS software to version 2.0, you must renumber the Norstar Voice Mail lines. Line 5 and greater will not be recognized by Norstar Voice Mail systems connected to a Compact ICS. Line 49 and greater will not be recognized by a Norstar Voice Mail system connected to a Modular ICS.

Renumbering the Norstar Voice Mail lines is divided into two parts:

- Running the line renumbering utility
- Resetting the Line Answer status

Before you start, ensure you have the **Line Renumbering Utility** diskette.

To run the line renumbering utility:

1. Press  9 1 5 .

2. Enter the default password 2 2 2 3 7 7 2 (ACCESS2) and press # .

3. Press ADMIN .

4. Press NEXT until the display shows:

5. Press SHOW .

6. Insert the **Line Renumbering Utility** diskette into the floppy disk drive of the NAM and press INSTL .

7. The display will continue to show progress as the line renumbering utility is running.

Remove the **Line Renumbering Utility** diskette from the floppy disk drive and press  .

### Resetting the Line Answer status

After the Norstar Voice Mail lines have been renumbered, you must reset the Line Answer status.

To reset Line Answer status:

1. Press  9 8 2 .

2. Enter the Operator password and press OK .

3. Press NEXT .

```
Business open: Y
CHNG          NEXT
```

4. Press NEXT .

```
Answer lines? Y
CHNG          NEXT
```

5. Press CHNG .

When Answer Lines is set to N the display shows: **Disabling...**

```
Answer lines? N
CHNG          NEXT
```

6. Press CHNG .

When Answer Lines is set to Y the display shows: **Enabling...**

```
Answer lines? Y
CHNG          NEXT
```

7. Press Rls to end this programming session.

The Norstar Voice Mail lines are now renumbered and will be answered as they were programmed.

---

# Section V - Troubleshooting

- Troubleshooting

## Overview

Troubleshooting Norstar Applications Module (NAM) problems involves determining the symptoms and diagnosing the cause of the problem.

A problem can be the result of more than one component failure. Diagnosing a NAM problem involves isolating the cause, and determining whether or not the malfunction involves a failed hardware component.

After you have determined the cause of the problem, and corrected the problem by replacing a component, you must test the NAM to determine whether or not it is functioning properly.

## Diagnosing problems

A malfunctioning NAM can be caused by a faulty component. This section describes the symptoms that occur when the NAM malfunctions. The section describes symptoms particular to hardware. The symptoms are described first, followed by procedures to confirm and correct the problem.



### **CAUTION**

Before attempting any repair procedures that require replacing internal components, attach one end of your grounding strap to your wrist and the other end to the Norstar Applications Server.

## Hardware problems

Hardware problems appear as any of the following:

- NAM does not function at all
- The Power-on tests fail
- The Power-on test run, but the download test do not
- Media Services Base Interface Card (BIC) is not functioning properly

**Note:** The procedures describe the components in the order of the most likely to cause the trouble.

**The NAM does not function at all**

If there is no response from the NAM or the Feature Codes do not appear on the Norstar display:

1. Make sure the:
  - AC power cord is plugged in
  - NAM is getting power from the AC outlet

**Note:** When the power is connected, the fan works.
2. Unplug the NAM and remove the front cover. Reseat the BIC. Check to ensure all ribbon cables and power supply connectors are properly connected.
3. Reseat the SBC located in slot 3. Check to ensure all ribbon cables are connected to the SBC.
4. Replace the front cover and plug in the NAM.

**The BIC is not functioning properly**

1. Check the setting of Auto Relocation on the Norstar System. Set it to Off. Refer to the *Norstar Installation Guide* for instructions.
2. Unplug the NAM and open the module door. Remove the two screws holding the front cover to the module. The screws are located along the top of the front cover. Slide the front cover out from the module.
3. Ensure that the BIC is seated properly in the expansion bus slot.
4. Plug in the NAM and give it time to complete the diagnostics.
5. Establish a Norstar Maintenance session. From a Norstar telephone connected to the KSU, access: **D. Maintenance** and **2. Port./Ext'n Stat.** Refer to the *Norstar Installation Guide* for instructions.
6. Display the type and state of the Channel connected to the Norstar KSU.
7. If the NAM is attached to a Centrex KSU, make sure all Channels are defined as Norstar only.

## Checking the Channel Status

Checking the Channel Status allows you to check each Channel for the following:

- If the Channel is installed
- If the Channel is idle
- If the Channel is currently receiving or dialling a call
- If the Channel is connected to a call
- If the Channel is connected to the KSU, but no application is using the Channel
- If the Channel is available, but has been not connected to the KSU
- Disable or re-enable a Channel

**Note:** Channel Status will show the status for all Channels. Channel Status will not identify the Channels as Voice or Fax.

To check the Channel Status:

1. Press  9 1 5 .

RETRY

2. Enter the default password        (ACCESS2).

3. Press NEXT until the display shows:

4. Press SHOW .

5. Press SHOW to show the status of a range of Channels. The first range shows Channel 1 to 8. The second range shows Channel 9 to 16. The third range shows Channel 17 to 24. The fourth range shows Channel 25 to 32. Press ALL to view all 32 Channels at once.

```
01-08 > cr....cc  
QUIT NEXT DETAIL
```

6. Press DETAIL for specific details about the individual Channels.

01-08 represents the first 8 Channels. The display cr....cc is an example of a display. Each of the 8 characters on the display signifies a Channel number. For example, Channel number one's status is c, Channel two's status is r. The display information is updated every two seconds. The information appearing on the display will vary depending on the number of Channels installed, or if other applications are installed and using Channels. Refer to Table 4 on page 106 for a definition of the Channel Status symbols.

**Note:** Press QUIT to return to the Channel Status Menu display.

```
1: 2235 2291
QUIT NEXT DSBL
```

7. Continue pressing **NEXT** to view the specific details about the remaining Channels.

The display **1: 2235 2291** is an example of a display. **1** is the number of the Channel. **2235** is the DN assigned to the Channel. The DN can be up to seven digits in length. **2291** is the DN of the extension that is currently connected to the Channel. This number can either be the line number being used or a DN. The number can be up to seven digits in length.

If the display shows **\*\*\*** in the last three characters on the display, the Channel is idle and not in use. For example, the display might show:

```
11: 2245 ***
```

**Note:** Specific details will only be available for Channel that are assigned an **a**, **.** or **r** in the Channel Status display in step 5.

If the display shows: **x: Not in sync** this means that the Channel has not been connected to the KSU and there is no DN assigned to the Channel.

If the display shows: **x: Not installed** this means that there is no Channel installed to the corresponding Channel number.

**Note:** The **x** in the display will be the number of the Channel.

```
xx: Not installed
QUIT NEXT
```

8. Press **[Rls]** to end this programming session.

If a new Channel has been connected to the KSU, you will have to quit the Channel Status session and re-enter Channel Status in order to view the changes.

Table 4 Channel Status Symbols

Channel Status Symbol	Definition of symbol
•	The Channel is installed and functioning, but is currently idle.
r	The Channel is ringing. The Channel is either receiving a call or is attempting to make a call.
c	The Channel is connected and is on an active call.
a	The Channel is connected to the KSU, but is not activated for any applications
×	A Channel is detected, but there is a connection problem.
*	No Channel

### Disabling and Re-enabling Norstar Voice Mail Channels

In the course of diagnosing a system problem you may find it necessary to disable a particular NAM Channel. After the problem has been solved, you will need to re-enable the Channel. If you attempt to disable all the Channels, the system will reboot itself.

To disable a Channel:

1. Press    .

```

Password:
          RETRY

```

2. Enter the default password        (ACCESS2).

```

ACCESS Server
BACK  NEXT  ADMIN

```

3. Press NEXT until the display shows.

```

Channel Status
BACK  NEXT  SHOW

```

4. Press SHOW.

```

Chan Status Menu
QUIT  ALL   SHOW

```

5. Press SHOW.

```

01-08 > ccc..crr
QUIT  NEXT  DETAIL

```

6. Press DETAIL.

```

1: 2225 ***
QUIT  NEXT  DSBL

```

7. Press NEXT until the Channel you want to disable is displayed.

```

3: 2227 ***
QUIT  NEXT  DSBL

```

8. Press DSBL.

```

3: Not in sync
QUIT  NEXT  ENBL

```

9. Press  to end this programming session.

To re-enable the Channel:

1. Press `Feature` `9` `1` `5` .

```

Password:
          RETRY
    
```

2. Enter the default password `2` `2` `2` `3` `7` `7` `2` (ACCESS2).

```

ACCESS Server
BACK  NEXT  ADMIN
    
```

3. Press `NEXT` until the display shows.

```

Channel Status
BACK  NEXT  SHOW
    
```

4. Press `SHOW` .

```

Chan Status Menu
QUIT  ALL   SHOW
    
```

5. Press `SHOW` .

```

01-08 >ccxxxcrn
QUIT  NEXT  DETAIL
    
```

6. Press `DETAIL` .

```

1: 2225 ***
QUIT  NEXT  DSBL
    
```

7. Press `NEXT` until the Channel you want to re-enable is displayed.

```

3: Not in sync
QUIT  NEXT  ENBL
    
```

8. Press `ENBL` .

```

3: 2227 ***
QUIT  NEXT  DSBL
    
```

9. Press `Rls` to end this programming session.

## Preparing the NAM for travel

Perform the following if you are returning the NAM to the factory for service or are mounting it in a new location.

1. Shutdown the NAM. For more information, refer to "Shutting down the NAM" on page 34.
2. Remove the NAM power cord from the AC outlet.
3. Unplug the BIC and any other cabling or wiring to the module.
4. Remove the two screws in the cable trough.
5. Grasp the module on its sides and gently lift straight up until the module is clear of the wall-mounting bracket.
6. If you are returning the NAM for service, pack it in its original shipping container. If the container is not available, package the module well with plenty of shock-absorbing, insulating material.

---

# Glossary

**Application**

A computer program that performs a wide range of tasks as specified by the user. Examples of application programs include word processing packages, spreadsheet packages and accounting packages.

**Backplane**

The backplane hosts the SBC and all other cards inserted in the NAM. The backplane connects the wiring between all circuits.

**Back up**

To make a duplicate copy of data files so that you can store the originals in a safe place. Backing up your original files protects them from damage if a hardware failure occurs.

**Baud rate**

A unit of measurement of data transmission speed. It is approximately equivalent to Bits Per Second (BPS). Typical baud rates are 300, 1200, 2400, 4800, and 9600.

**Bit**

An abbreviation for Binary Digit. A bit is the smallest unit of information recognized by the computer. A bit has one of two values (0 or 1) to indicate off or on.

**BIOS (Basic Input Output System)**

A program contained in Read Only Memory (ROM) that acts as the interface between software programs and the computer hardware.

**BPS (Bits Per Second)**

The speed of data transmission between two computers.

**Bus**

A collection of communication lines that carry electronic signals either between elements on the system board or between the circuitry on the system board and any cards plugged into the system board.

**Byte**

The amount of space required to store a single character. One byte equals eight bits.

**CD-ROM (Compact Disc Read Only Memory)**

The CD-ROM drive and the accompanying CD-ROM disk are used to upgrade the system software.

**Conventions**

The way certain information is described. For example, using underlined text to represent second-line display prompt information.

**Default**

The parameters that are preset within the NAM.

**Disk drive**

A mass storage device that seeks, reads and writes data on a disk.

**Diskette**

A removable magnetic disk used to store data.

**Display**

A one-line or two-line screen on a Norstar telephone that shows commands and options.

**Display buttons**

The three buttons that appear underneath a Norstar two-line LCD display.

**Display options**

The choices available to a user that appear on the Norstar two-line display. Options appearing on the display can be selected using the display or dialpad buttons.

**Driver (Device)**

A program that allows a hardware peripheral, such as a NIC, to communicate with the NAM.

**Ethernet**

A widely used Local Area Network (LAN) protocol that is the original Carrier Sense Multiple Access/Collision Detect (CSMA/CD) LAN that lets PCs and/or NAMs listen for pauses before they communicate. Ethernet LANs use coaxial cable or twisted pair wiring for connecting computers.

**FAX**

FAX works with Norstar Voice Mail and Norstar, offering a caller the capability of sending a fax document to a mailbox as easily as sending a voice message.

**Feature Code**

A unique three-digit code used to access NAM Features and options.

**File**

A collection of related information stored on a disk under a given name for later reference and used by an operating system or application program. Each application program that you use saves the data you create in files. Files are identified by a file name and optional extension.

**File name**

A name that identifies a file and consists of one to eight characters.

**Fully Qualified Domain Name (FQDN)**

The combination of host name and domain name. For example mycomputer.nortel.com is Fully Qualified Domain Name.

**Hard disk drive**

A data storage device that uses non-removable, rigid magnetic platters. Hard disk drives work faster and store more data than disk drives do for diskettes.

**Hardware**

The physical components of the NAM.

**Host Name**

In networking, the name of a computer that primarily provides services, such as database access, to other computers or NAMs in the domain. The host name is associated with a unique IP address. Since the NAM has a unique IP address, it qualifies as a host.

**Hz (hertz)**

A unit of measure for indicating frequency in cycles per second.

**Initialization**

The steps required to prepare hardware or software for operation.

**Install**

To set up for operation. For example, hardware is installed by attaching it to the appropriate connectors or sockets either inside or outside the NAM.

**Interface**

An information interchange path that allows communication between computer parts.

**Internet**

A global TCP/IP network linking millions of computers for communications purposes.

**IRQ (Interrupt Request)**

A signal sent by a hardware device to the microprocessor requesting its immediate attention. For example, each communications port has an interrupt request line for notifying the microprocessor when data has been received or transmitted.

**IRQ Conflict**

Two hardware devices are vying for same IRQ. On installation of a device where an IRQ conflict occurs, the user may have to manually configure the IRQ settings to resolve the conflict.

**Industry Standard Architecture (ISA)**

A 16-bit socket on the NAM's backplane.

**Kbyte**

The abbreviation for kilobyte. A kilobyte is equal to 1024 bytes.

**Local Area Network (LAN)**

A group of computers or NAMs physically connected in a manner that lets them communicate and interact with each other.

**Mailbox**

A storage place for messages on the Norstar Voice Mail system.

**MHz**

The abbreviation for megahertz. This is a unit of measure indicating frequency in millions of cycles per second.

**Microprocessor**

A chip that is the centre of all activity inside the Applications Module. The microprocessor controls all logical and arithmetic operations for the computer and is responsible for executing program commands. It is also referred to as the Central Processing Unit (CPU).

**Modem**

A communications device that allows data to be exchanged between computers over telephone lines. The exchange is done by electronic processes called modulation and demodulation. The modem changes (modulates) the data into tones to send to another modem and also converts (demodulates) tones when receiving from another modem.

**M7100 telephone**

The Norstar model M7100 telephone that has a single-line display and one programmable button without an indicator.

**M7208 telephone**

The Norstar model M7208 telephone that has a single-line display and eight programmable button with indicators.

**M7310 telephone**

The Norstar model M7310 telephone that has a two-line display with three display button, 10 programmable button with indicators and 12 dual programmable button without indicators.

**M7324 telephone**

The Norstar model M7324 telephone that has a two-line display with three display button and 24 programmable buttons with indicators.

**Network**

Two or more computers linked together electronically to share programs and exchange data. Joining computers over a network requires adding specialized hardware and software to each computer.

**Network Interface Card (NIC)**

An adapter card, inserted into a slot 5 of the NAM, containing the hardware necessary to connect a NAM to a network.

**Operating system**

The disk-based software that manages the operation of the Applications Module. An operating system controls the flow of information between the computer hardware such as the keyboard, video display, disk drives and printer. IBM OS/2 is the operating system that manages the Applications Module.

**Option**

A NAM choice that is given to a user through display prompts.

**Parallel port**

A port that transfers data through multiple wires so that eight bits are transmitted simultaneously. Parallel ports usually use a 25-pin interface that transmits and receives data one byte at a time using a separate data line for each bit.

**Password**

A four-digit to eight-digit number that is entered using the dialpad. A password is used to open mailboxes or perform configuration tasks.

**PEB (PCM Expansion Bus)**

A PEB cable is used to connect the BEC to the Digital Fax Card (DFC) when the FAX option is installed.

**Peripheral**

A device that is connected to and communicates with a computer. A printer and mouse are peripherals.

**Peripheral Component Interconnect (PCI) Slot**

A socket on the NAM's backplane that allows for faster communication between the NAM's CPU and peripheral components.

**Pin-1**

The first pin in a multiple-pin connector or chip designated as such to help you properly orient the component when attaching or installing it.

**Port**

A connector on the Applications Module that allows data exchange with other devices, such as a printer, mouse or external modem.

**Protocol**

A set of rules and procedures for exchanging data between computers or NAMs on a network or through the Internet.

**Power cable**

A cable that connects the NAM to a power source.

**RAM (Random Access Memory)**

Computer memory that stores data temporarily. RAM stores the data used by the microprocessor as it executes instructions. The contents of RAM are erased each time the Applications Module is turned off or restarted.

**ROM (Read Only Memory)**

Memory that stores data permanently. ROM contains instructions that the Applications Module needs to operate. The instructions stored in ROM cannot be changed and are used by the Applications Module each time it is turned on or restarted.

**Routing**

The path a message takes from its point of origin to its destination on a network or the Internet.

**Serial port**

A port that sends and receives data one bit at a time. This port can be used to connect the Applications Module to a printer, external modem or mouse. Serial port connectors usually have nine pins and are designated by software with the letters COM and a single digit, such as COM1.

**Single Board Computer (SBC)**

The Single Board Computer is the main computing device of the NAM. It runs the operating system and all applications installed on the NAM. The microprocessor, clock/calendar battery and four Single In-Line Memory Modules (SIMM) slots are located on the SBC.

**SIMM**

Single In-line Memory Module. The NAM is equipped with one SIMM that provides 16 MB of EDO RAM. The memory can be increased with the addition of more SIMMs.

**SVGA**

Super Video Graphics Array. The video graphics standard that supports 800X600 graphic resolution and 1024X768 to 1280X960 text resolution displaying up to 256 colors.

**Tone dial telephone**

A push button telephone that emits DTMF tones.

**Transmission Control Protocol/Internet Protocol (TCP/IP)**

A language governing communication among all computers on the Internet.

TCP protocol checks packets of information for errors, submits requests for re-transmission in the event of errors and returns multiple packets of a message into the proper original sequence when the message reaches its destination.

IP dictates how packets are sent out over networks and has a packet addressing method that lets any computer on the Internet forward a packet to any other computer that is a step or more closer to the packet's recipient.

**Wide Area Network (WAN)**

A collection of computers or NAMs connected or networked to each other over long distances, typically using common carrier facilities.

# Index

## A

- ACCESS Server 17
- ACCESS Server admin 86, 91
  - Alarms 87
  - From a telephone set 86
  - Installing applications 91
  - Printer options 86
  - Rebooting the NAM 92
  - Scheduled reboot 93
  - Shutting down the NAM 92
  - Voice Channel sharing 88
  - Voice Channels 88
- Alarms 87
  - Viewing log 87
- Applications, installing 91

## B

- Back up, capabilities file 59
- Battery
  - Installing 40
  - Removing 39

## C

- Cable trough door 35
- Cable trough, opening 37
- Capabilities file
  - backing up 59
- Case 37
- Caution symbol 10
- Channel status 103
- Channels 51
  - Allocating 88
  - disabling 106
  - Re-enabling 107
- Checking the Channel status 103
- Clock/calendar, removing 39
- Conventions and symbols 10

## D

- DB 25-pin 15
  - Connector 15
- Diagnosing 101
- Digit duration length 86
- Digital Fax Card (DFC)
  - expansion bus slot 42
  - Installation precautions 42
  - Installing 42
  - Installing PEB cable 46
  - Number of ports 46

- Overview 41
- PEB cable 46
- Removing Fax from the System 48
- Documents, required 22
- Door 35
- Drive
  - Secondary hard drive 64
- Drives
  - floppy disk 14
- Drive, floppy 57
- DTMF 86

## E

- Enabling the monitor 74
- Enabling the monitor, keyboard and mouse 74
- End-caps 27
- Environment 22

## F

- Fax card
  - Overview 41
  - Slot 42
- Fax card, installing 42
- Fax Channel sharing 88
- Fax Channels
  - Allocating 88
- Fax ports, number of 46
- Fax, removing functionality 48
- FCC regulations i
- Floor mount stand
  - Assembling 25
  - Attaching to the NAM 26
  - Installing the end-caps 27
- Floppy disk drive 14
  - Installing 57
  - Removing 57
- Front cover 35, 36
  - Removing 36
- Front door 35

## H

- Hanging the NAM 23
- Hard disk drive
  - Adding a secondary 64
  - Installing a new one 62
  - Removing 60
- Hard drive, space 59
- Hardware 13, 14, 16
  - Components 13

- Floppy disk drive 14
- Modem 16
- Network Interface Card 16
- Ports 15
- Printer 16
- Hardware, problems 101
- I**
- IBM OS/2 Warp™ Operating system 17
- Installation overview 23
- Installation requirements 22
- Installation tools 22
- Installing
  - Digital Fax Card 42
- Installing an application 91
- Internal components
  - Hard disk drive 62
- K**
- Keyboard
  - Enabling 74
  - Removing 75
- L**
- LAN card 16
- M**
- Manual, organization 9
- Manual, overview 9
- Memory
  - Adding 67
  - Expansion capabilities 13, 67
  - Removing 70
- Module parts
  - Door 35
- Monitor
  - Enabling 74
  - Removing 75
- Monitor package
  - Enabling 74
  - Installing the SVGA 44, 73
  - Removing 75
- Monitor, keyboard and mouse
  - Enabling 74
- Mounting the NAM 23
- Mouse
  - Enabling 74
  - Removing 75
- N**
- NAM
  - ACCESS Server 17
  - Adding memory 67
  - Attaching a stand 26
  - Backing up the capabilities file 59
  - Cable trough 37
  - Connection points 15
  - Digital Fax Card (DFC) slot 42
  - Fax ports 46
  - Floppy disk drive 14, 57
  - Hard disk drive 59, 62
  - Hardware components 13
  - Installing a DFC 42
  - Installing a PEB cable 46
  - Installing clock/calendar battery 40
  - Installing the SVGA 44, 73
  - Interior components 13
  - Memory 13
  - Monitor package 74, 75
  - Mounting 23
  - Operating system 17
  - Optional equipment 16
  - Packing 108
  - Parallel Port 15
  - Parallel port 15
  - Parts 35
  - PEB cable 46
  - Plastic case
  - Ports 15
  - Printer 15
  - Rebooting 92
  - Removing Fax 48
  - Removing the front cover 36
  - Removing the hard disk drive 60
  - Restoring the capabilities file 63
  - Secondary hard disk drive 64
  - Serial number 91
  - Serial Ports 15
  - Shutting down 34, 92
  - shutting down 34
  - Single Board Computer (SBC) 13, 79, 80, 81
  - Software hierarchy 17
  - Stand 25
  - System software 17
  - Tools 34
  - Troubleshooting 101
  - Voice Channels 51
  - Voltage 23
- NAM serial Number 91
- Network Interface Card 16
- O**
- Operating system 17
- Optional equipment 16
  - Modem 16
  - Monitor package 16
  - Network Interface Card 16
  - Printer 16

OS/2 Warp™ 17

## P

Parallel port 15  
 PCM Expansion Bus (PEB) cable 46  
   Installing 46  
 PEB cable 46  
   Installing 46  
 Pin configuration 15  
 Pin connector 15  
 Plastic case 35  
   NAM 37  
   Removing 37  
 Port sharing 88  
 Ports 15  
   Fax 46  
   Parallel 15  
   Printer 15  
   Serial 15  
 Power supply  
   Changing 23  
 Printer 15, 86  
   Changing options 86  
 Printer connection 15  
 Processor 13

## R

Rebooting the NAM 92  
 Regulatory information i  
 Removing Fax 48  
 Repair equipment 34  
 Repair facilities i, iv  
 Requirements  
   Environment 22  
   Package 21  
 Requirements,  
   Special parts 22  
 Restoring 63  
   Capabilities file 63  
 Returning the NAM 108

## S

Scheduled reboot 93  
 Secondary hard disk drive 64  
 Serial number, viewing 91  
 Serial port 15  
   Pin configuration 15  
 Setting the DTMF 86  
 Sharing 88  
 Sharing, Channels 88  
 Shutting down NAM  
   Graceful 34  
   Immediate 34

Quick 34

Shutting down the NAM 92  
 SIMMs 13, 67  
   Removing 70  
 Single Board Computer (SBC) 13  
   Installing 81  
   Overview 79  
   Removing 80  
   Replacing 80  
 Software 17  
   ACCESS 17  
   hierarchy 17  
   System 17  
 Stand, NAM 25  
 SVGA video card 44  
 SVGA video card on the SBC 73  
 Symbols 10  
 System Software 17

## T

Tools, for repairs 34  
 Troubleshooting  
   Channels 103, 106  
   Diagnosing problems 101  
   Hardware 101  
 Trough, cable 37

## U

Upgrades  
   Memory 67  
 uses for 15

## V

Video card  
   Enabling 74  
   Installed on SBC 73  
   Installing 73  
 Voice Channel sharing 88  
 Voice Channels 51  
   Allocating 88  
   Increasing number 51  
   Re-enabling 107  
 Voltage of the NAM 23

## W

Warning symbol 10